

EJX and EJA-E Series Differential Pressure and Pressure Transmitters Installation Manual

IM 01C25A01-01E



Contents

1. Introduction	
1.1 For Safe Use of Product.....	3
1.2 Warranty.....	4
2. Handling Cautions	
2.1 Model and Specifications Check.....	6
2.2 Selecting the Installation Location	6
2.3 Pressure Connection	6
2.4 Installation of an Explosion-Protected Instrument	7
2.5 EMC Conformity Standards	32
2.6 Pressure Equipment Directive (PED)	32
2.7 EU RoHS Directive.....	33
2.8 Safety Requirement Standards.....	33
3. Installation	
3.1 Mounting.....	34
3.2 Mounting the Diaphragm Seals	36
3.3 Diaphragm Seals Installation Consideration.....	37
3.4 Mounting the Flushing Connection Ring.....	38
3.5 Affixing the Teflon Film	39
3.6 Rotating Transmitter Section.....	40
3.7 Changing the Direction of Integral Indicator.....	40
4. Installing Impulse Piping	
4.1 Impulse Piping Installation Precautions	41
4.2 Impulse Piping Connection Examples	44
4.3 Process Piping Installation Precautions (EJ□115□)44	
5. Wiring	
5.1 Wiring Precautions	46
5.2 Connections of External Wiring to Terminal Box.....	46
5.3 Wiring	49
5.4 RTD Cable Connection (EJX910A/EJX930A).....	51
5.5 Grounding	55
5.6 Power Supply Voltage and Load Resistance.....	55
6. Operation	
6.1 Preparation for Starting Operation.....	56
6.2 Zero Point Adjustment.....	56
6.3 Local Parameter Setting	57
7. Errors and Countermeasures	



1. Introduction

This installation manual provides the basic guidelines for installation and wiring procedures of the DPharp EJX series and EJA-E series transmitters with BRAIN and HART protocols and is composed of the information extracted from the product users' manuals as listed in Table 1.1. It does not provide the information including wiring procedures of the transmitters with FOUNDATION Fieldbus, Profibus and Modbus protocols, product specific functional specifications and explanations, operation, maintenance and trouble-shooting.

For EJXC40A Digital Remote Sensor, as this Installation Manual does not cover the product, please refer to the dedicated manual for EJXC40A.



WARNING

To ensure correct and safe use of the instrument, obtain the manuals and General Specifications sheets applicable to designated models and specifications as listed Table 1.1 and 1.2, read them thoroughly and fully understand how to operate the instrument before operating it.

Users' manual for each product consists of a hardware manual describing installation, wiring, operation, and maintenance and a communication manual describing information specific to each communication protocol type, including safety manual for safety instrumented system. The specifications of each product including external dimensions and detailed model and suffix codes are described in General Specifications sheet(GS.)

These manuals and GSs can be downloaded from the website of Yokogawa, and printed manuals can also be purchased from the Yokogawa representatives.

Website address:

<https://www.yokogawa.com/solutions/products-platforms/field-instruments/>

Table 1.1 PDF Manual List and Applicable Style Code

[EJX series Hardware Manual]

Models	Document No.	Style
EJX110A	IM 01C25B01-01E	S3
EJX120A		S1
EJX130A, EJX310A, EJX430A and EJX440A		S2
EJX210A	IM 01C25C01-01E	S2
EJX510A and EJX530A	IM 01C25F01-01E	S2
EJX610A and EJX630A		S1
EJX118A and EJX438A	IM 01C25H01-01E	S2
EJX115A	IM 01C25K01-01E	S1
EJX910A	IM 01C25R01-01E	S2
EJX930A		S1
EJXC80A and EJXC50A	IM 01C25W01-01EN	—
EJXC40A	IM 01C25W05-01EN	—

[EJX series Communication Manual]

Models	Document No.	Style
DPharp HART 5/HART 7 Communication Type	IM 01C25T01-06EN	—
DPharp FOUNDATION Fieldbus Communication Type	IM 01C25T02-01E	—
DPharp BRAIN Communication Type	IM 01C25T03-01E	—
DPharp PROFIBUS PA Communication Type	IM 01C25T04-01EN	—
EJX910A and EJX930A HART Communication Type	IM 01C25R02-01E	—
EJX910A and EJX930A Fieldbus Communication Type	IM 01C25R03-01E	—
EJX910A and EJX930A Modbus Communication Type	IM 01C25R05-01E	—

[EJA-E series Hardware Manual]

Models	Document No.	Style
EJA110E, EJA120E	IM 01C25B01-01E	S1,S2
EJA130E, EJA310E, EJA430E and EJA440E		
EJA210E		
EJA510E and EJA530E	IM 01C25F01-01E	S1,S2
EJA118E and EJA438E	IM 01C25H01-01E	S1,S2
EJA115E	IM 01C25K01-01E	S1,S2
EJAC80E and EJAC50E	IM 01C25W01-01EN	—

[EJA-E series Communication Manual]

Models	Document No.	Style
DPharp HART 5/HART 7 Communication Type	IM 01C25T01-06EN	—
DPharp FOUNDATION Fieldbus Communication Type	IM 01C25T02-01E	—
DPharp BRAIN Communication Type	IM 01C25T03-01E	—
DPharp PROFIBUS PA Communication Type	IM 01C25T04-01EN	—

Note: An exclusive User's Manual might be attached for the products whose suffix codes or optional codes contain code "Z". Please read it along with the standard manuals.

■ General Specifications List

Model	Document No.
EJX110A	GS 01C25B01-01EN
EJX120A	GS 01C25B03-01EN
EJX130A	GS 01C25B04-01EN
EJX210A	GS 01C25C01-01EN
EJX310A	GS 01C25D01-01EN
EJX430A	GS 01C25E01-01EN
EJX440A	GS 01C25E02-01EN
EJX510A, EJX530A	GS 01C25F01-01EN
EJX610A, EJX630A	GS 01C25F05-01EN
EJX118A	GS 01C25H01-01EN
EJX118A	GS 01C25H01-11EN
EJX438A	GS 01C25J03-01EN
EJX438A	GS 01C25J03-11EN
EJX115A	GS 01C25K01-01EN
EJX910A	GS 01C25R01-01EN
EJX930A	GS 01C25R04-01EN
EJXC50A, EJXC40A, EJAC50E, EJXC80A, EJAC80E, EJXC81A, EJAC81E	GS 01C25W01-01EN
EJXC40A	GS 01C25W05-01EN
EJX110A, EJX130A	GS 01C25V01-01EN
EJX110A	GS 01C25V02-01EN
EJX-A, EJA-E Marine certificate	GS 01C25A02-01EN
EJA110E	GS 01C31B01-01EN
EJA120E	GS 01C31B03-01EN
EJA130E	GS 01C31B04-01EN
EJA210E	GS 01C31C01-01EN
EJA310E	GS 01C31D01-01EN
EJA430E	GS 01C31E01-01EN
EJA440E	GS 01C31E02-01EN
EJA510E, EJA530E	GS 01C31F01-01EN
EJA118E	GS 01C31H01-01EN
EJA118E	GS 01C31H01-11EN
EJA438E	GS 01C31J03-01EN
EJA438E	GS 01C31J03-11EN
EJA115E	GS 01C31K01-01EN
EJAC60E, EJA560E	GS 01C31Y01-01EN
EJA110E, EJA130E	GS 01C31V01-01EN
EJA110E	GS 01C31V02-01EN

■ Regarding This Manual

- This manual should be passed on to the end user.
- The contents of this manual are subject to change without prior notice.
- All rights reserved. No part of this manual may be reproduced in any form without Yokogawa's written permission.
- Yokogawa makes no warranty of any kind with regard to this manual, including, but not limited to, implied warranty of merchantability and fitness for a particular purpose.
- If any question arises or errors are found, or if any information is missing from this manual, please inform the nearest Yokogawa sales office.
- The specifications covered by this manual are limited to those for the standard type under the specified model number break-down and do not cover custom-made instruments.
- Please note that changes in the specifications, construction, or component parts of the instrument may not immediately be reflected in this manual at the time of change, provided that postponement of revisions will not cause difficulty to the user from a functional or performance standpoint.
- Yokogawa assumes no responsibilities for this product except as stated in the warranty.
- If the customer or any third party is harmed by the use of this product, Yokogawa assumes no responsibility for any such harm owing to any defects in the product which were not predictable, or for any indirect damages.
- When describing the model name like EJ□110□ in this manual, it shows the applicability for both EJX110A and EJA110E. The same representations are used for the other models, too.
- The following safety symbol marks are used in this manual:



WARNING

Indicates a potentially hazardous situation which, if not avoided, could result in death or serious injury.



CAUTION

Indicates a potentially hazardous situation which, if not avoided, may result in minor or moderate injury. It may also be used to alert against unsafe practices.



IMPORTANT

Indicates that operating the hardware or software in this manner may damage it or lead to system failure.



NOTE

Draws attention to information essential for understanding the operation and features.



Direct current



Functional grounding terminal



Caution

This symbol indicates that the operator must refer to an explanation in the user's manual in order to avoid the risk of injury or death of personnel or damage to the instrument.

1.1 For Safe Use of Product

For the protection and safety of the operator and the instrument or the system including the instrument, please be sure to follow the instructions on safety described in this manual when handling this instrument. In case the instrument is handled in contradiction to these instructions, Yokogawa does not guarantee safety. Please give your attention to the followings.

(a) Installation



WARNING

- The instrument must be installed by an expert engineer or a skilled personnel. The procedures described about INSTALLATION are not permitted for operators.
- In case of high process temperature, care should be taken not to burn yourself because the surface of body and case reaches a high temperature.
- The instrument installed in the process is under pressure. Never loosen the process connector bolts to avoid the dangerous spouting of process fluid.
- During draining condensate from the pressure detector section, take appropriate care to avoid contact with the skin, eyes or body, or inhalation of vapors, if the accumulated process fluid may be toxic or otherwise harmful.
- When removing the instrument from hazardous processes, avoid contact with the fluid and the interior of the meter.
- All installation shall comply with local installation requirement and local electrical code.

(b) Wiring



WARNING

- The instrument must be installed by an expert engineer or a skilled personnel. The procedures described about WIRING are not permitted for operators.
- Please confirm that voltages between the power supply and the instrument before connecting the power cables and that the cables are not powered before connecting.

(c) Operation



WARNING

- Wait 5 min. after power is turned off, before opening the covers.
- Do not open the cover in wet weather or humid environment. If the cover is opened, stated enclosure protection is not applicable.

(d) Maintenance



WARNING

- Please do not carry out except being written to maintenance descriptions. When these procedures are needed, please contact nearest YOKOGAWA office.
- Care should be taken to prevent the build up of drift, dust or other material on the display glass and name plate. In case of its maintenance, soft and dry cloth is used.

(e) Explosion Protected Type Instrument



WARNING

- Users of explosion proof instruments should refer first to section 2.4 (Installation of an Explosion Protected Instrument) of this manual.
- For TIIS flameproof type instruments, be sure to read "INSTALLATION AND OPERATING PRECAUTIONS FOR TIIS FLAMEPROOF EQUIPMENT" at the end of this manual.
- The use of this instrument is restricted to those who have received appropriate training in the device.
- Take care not to create sparks when accessing the instrument or peripheral devices in a hazardous location.

(f) Modification**WARNING**

- Yokogawa will not be liable for malfunctions or damage resulting from any modification made to this instrument by the customer.

(g) Product Disposal

The instrument should be disposed of in accordance with local and national legislation/regulations.

(h) Authorized Representative in EEA and the importer into the EU/EEA market

In relation to the CE Marking, The authorized representative for this product in the EEA (European Economic Area) is:

Yokogawa Europe B.V.

Euroweg 2, 3825 HD Amersfoort, The Netherlands and the importer for this product into the EU/EEA market via the YOKOGAWA sales channel is:

Yokogawa Europe B.V.

Euroweg 2, 3825 HD Amersfoort, The Netherlands

(i) Control of Pollution Caused by the Product

Please refer to the IM 01C00A20-01ZH for information on our management status pursuant to “Control of Pollution caused by Electronic Information Products” of the People’s Republic of China. Please search for the IM number in the Yokogawa library “ <https://www.yokogawa.com/library/> ”.

(j) Morocco conformity mark 

This conformity mark indicates that the product complies with Moroccan safety and EMC requirements.

1.2 Warranty

- The warranty shall cover the period noted on the quotation presented to the purchaser at the time of purchase. Problems occurred during the warranty period shall basically be repaired free of charge.
 - In case of problems, the customer should contact the Yokogawa representative from which the instrument was purchased, or the nearest Yokogawa office.
 - If a problem arises with this instrument, please inform us of the nature of the problem and the circumstances under which it developed, including the model specification and serial number. Any diagrams, data and other information you can include in your communication will also be helpful.
 - Responsible party for repair cost for the problems shall be determined by Yokogawa based on our investigation.
 - The Purchaser shall bear the responsibility for repair costs, even during the warranty period, if the malfunction is due to:
 - Improper and/or inadequate maintenance by the purchaser.
 - Failure or damage due to improper handling, use or storage which is out of design conditions.
 - Use of the product in question in a location not conforming to the standards specified by Yokogawa, or due to improper maintenance of the installation location.
 - Failure or damage due to modification or repair by any party except Yokogawa or an approved representative of Yokogawa.
 - Malfunction or damage from improper relocation of the product in question after delivery.
 - Reason of force majeure such as fires, earthquakes, storms/floods, thunder/lightening, or other natural disasters, or disturbances, riots, warfare, or radioactive contamination.
- **Trademarks:**
- ‘DPharp’, ‘EJX’, ‘EJA’, ‘FieldMate’ and ‘BRAIN TERMINAL’ are registered trademarks of Yokogawa Electric Corporation. Company names and product names used in this material are registered trademarks or trademarks of their respective owners.
 - In this manual, trademarks or registered trademarks are not marked with TM or ®.

2. Handling Cautions

When the transmitter is delivered, visually check them to make sure that no damage occurred during shipment. Also check that all transmitter mounting hardware shown in Figure 2.1 is included. If the transmitter was ordered without the mounting bracket or without the process connector, the transmitter mounting hardware is not included.

Table 2.1 Applicable Model Code for Mounting Hardware

Applicable model	Suffix code	Part name	Qty		
EJ□110□	Process connections 1,2,3 and 4	Process connector bolt	4*		
EJ□120□		Process connector	2*		
EJ□130□		Process connector gasket	Process connector gasket	2*	
EJX910A			Process connector bolt	2	
EJX930A			Process connector	1	
EJ□210□	Process connections 1,2,3 and 4	Process connector gasket	1		
EJ□310□		Process connector bolt	2		
EJ□430□		Process connector	1		
EJ□440□		Process connector gasket	1		
EJ□110□	Mounting bracket B,D,G,J and K	U-bolt	1		
EJ□120□		U-bolt nut	U-bolt nut	2	
EJ□130□			Mounting bracket (L or flat type)	Mounting bracket (L or flat type)	1
EJ□310□		Transmitter mounting bolt		Transmitter mounting bolt	4
EJ□430□				U-bolt	1
EJ□440□		U-bolt nut	2		
EJ□118□		Mounting bracket	1		
EJ□438□		Transmitter mounting bolt	2		
EJ□115□	Mounting bracket M (For measurement span code other than F)	U-bolt	1		
EJX910A		U-bolt nut	2		
EJX930A		Mounting bracket	1		
		Transmitter mounting bolt	2		
EJ□510□	Mounting bracket F and L	U-bolt (L and S)	1 ea.		
EJ□530□		U-bolt nut (L and S)	2 ea.		
EJX610A		Mounting bracket	1		
EJX630A	External temperature input B, C and D	RTD cable	1		
EJX910A		External temperature input 1, 2, 3 and 4	Cable gland	2	
EJX930A	Option code /TF1		Teflon film	1	
EJ□210□		Fluorinated oil	1		
EJ□438□	Option code /TF1	Teflon film	2		
EJ□118□		Fluorinated oil	2		

Applicable model	Suffix code	Part name	Qty	
EJ□110□	Mounting bracket P	U-bolt	1	
EJ□120□		U-bolt nut	2	
EJ□130□		Mounting bracket (L or flat type)	1	
EJ□310□		Plate	1	
EJ□430□		Position adjusting screw	4	
EJ□440□		Transmitter mounting bolt	Transmitter mounting bolt	4
EJX910A				
EJX930A				

*: When /BS is specified, the amount becomes half.

EJ□110□		B
EJ□120□	1	D
EJ□130□	2	G
EJ□310□	3	J
EJ□430□	4	K
EJ□440□		M
		P
		B 1
		D 2
		G 3
EJX910A	1	J 4
EJX930A	2	K B
	3	M C
	4	P D
	1	
EJ□210□	2	
	3	
	4	
EJ□510□		
EJ□530□		F
EJX610A		L
EJX630A		
EJ□118□		B
EJ□438□		J
		B
		D
EJ□115□		J
		K
		P

F0201.ai

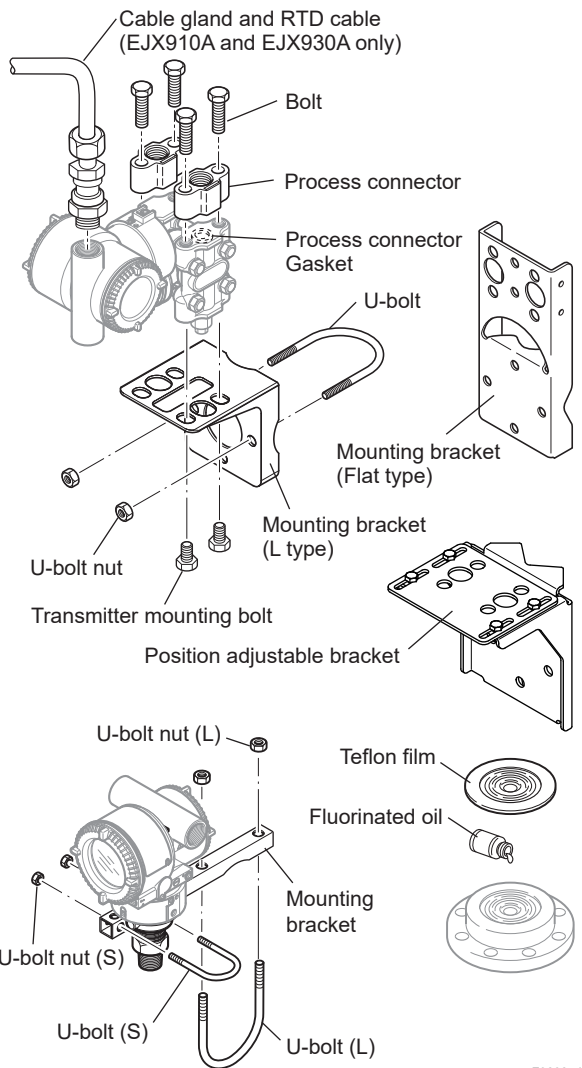

F0202.ai

Figure 2.1 Transmitter Mounting Hardware

2.1 Model and Specifications Check

The model name and specifications are indicated on the name plate attached to the case.

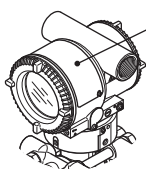
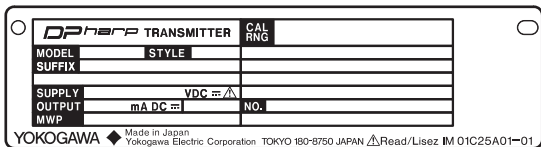

F0203.ai

Figure 2.2 Name Plate

2.2 Selecting the Installation Location

The transmitter is designed to withstand severe environmental conditions. However, to ensure that it will provide years of stable and accurate performance, take the following precautions when selecting the installation location.

- (a) Ambient Temperature
Avoid locations subject to wide temperature variations or a significant temperature gradient. If the location is exposed to direct sunlight or radiant heat from plant equipment, provide adequate shade, thermal insulation and/or ventilation.
- (b) Ambient Atmosphere
Do not install the transmitter in a corrosive atmosphere. If this cannot be avoided, there must be adequate ventilation as well as measures to prevent the leaking of rain water and the presence of standing water in the conduits.
- (c) Shock and Vibration
Although the transmitter is designed to be relatively resistant to shock and vibration, an installation site should be selected where this is kept to a minimum.
- (d) Installation of Explosion-protected Transmitters
An explosion-protected transmitters is certified for installation in a hazardous area containing specific gas types. See subsection 2.4 "Installation of an Explosion-Protected Instrument."

2.3 Pressure Connection



WARNING

- Never loosen the process connector bolts when an instrument is installed in a process. The device is under pressure, and a loss of seal can result in a sudden and uncontrolled release of process fluid.
- When draining toxic process fluids that have condensed inside the pressure detector, take appropriate steps to prevent the contact of such fluids with the skin or eyes and the inhalation of vapors from these fluids.

The following precautions must be observed in order to safely operate the transmitter under pressure.

- (a) Make sure that the process connector bolts are tightened firmly.
- (b) Make sure that there are no leaks in the impulse piping.
- (c) Never apply a pressure higher than the specified maximum working pressure.

2.4 Installation of an Explosion-Protected Instrument

If a customer makes a repair or modification to an intrinsically safe or explosionproof instrument and the instrument is not restored to its original condition, its intrinsically safe or explosionproof construction may be compromised and the instrument may be hazardous to operate. Please contact Yokogawa before making any repair or modification to an instrument.



CAUTION

This instrument has been tested and certified as being intrinsically safe or explosionproof. Please note that severe restrictions (e.g. IEC 60079-14) apply to this instrument's construction, installation, external wiring, maintenance and repair. A failure to abide by these restrictions could make the instrument a hazard to operate.



WARNING

Maintaining the safety of explosionproof equipment requires great care during mounting, wiring, and piping. Safety requirements also place restrictions on maintenance and repair. Please read the following sections very carefully.



WARNING

The range setting switch must not be used in a hazardous area.



IMPORTANT

For combined approval types
Once a device of multiple approval type is installed, it should not be re-installed using any other approval types. Apply a permanent mark in the check box of the selected approval type on the certification label on the transmitter to distinguish it from unused approval types.



IMPORTANT

All the blind plugs which accompany the EJX/EJA-E transmitters upon shipment from the factory are certified by the applicable agency in combination with those transmitters. The plugs which are marked with the symbols "◇ Ex" on their surfaces are certified only in combination with the EJX/EJA-E series transmitters.

2.4.1 FM Approval

a. FM Intrinsically Safe/Nonincendive for HART/BRAIN Protocol Type (Except for EJX9□0A)

Note 1. EJX/EJA-E Series pressure transmitters with optional code /FS1 are applicable for use in hazardous locations.

- Applicable Standard:
 - FM 3600:2011
 - FM 3610:2010
 - FM 3611:2004
 - FM 3810:2005
 - ANSI/ISA-60079-0-2009
 - ANSI/ISA-60079-11-2009
 - ANSI/ISA-61010-1-2004
 - NEMA 250:1991
- Rating
 - Intrinsically Safe for
 - Class I, II, III Division 1,
 - Groups A, B, C, D, E, F, G T4
 - Class I Zone 0 AEx ia IIC T4
 - Nonincendive for
 - Class I, II, III Division 2
 - Groups A, B, C, D, F, G T4
 - Class I, Zone 2 Group IIC T4
- Ambient temperature: -60 to 60°C
- Enclosure: Type 4X

Note 2. Installation
Installation should be in accordance with Control Drawing IFM022-A12.

Note 3. Specific conditions of use:
Precautions shall be taken to minimize the risk from electrostatic discharge of painted parts.
When the enclosure of the Pressure Transmitters is made of aluminum alloy, if it is mounted in Zone 0, it shall be installed such that, even in the event of rare incidents, an ignition source due to impact and/or friction sparks is excluded.

Note 4. Maintenance and Repair
 Only personnel authorized by Yokogawa Electric Corporation can repair the equipment.

Model: EJX Series Date: October 22, 2003
 Control Drawing

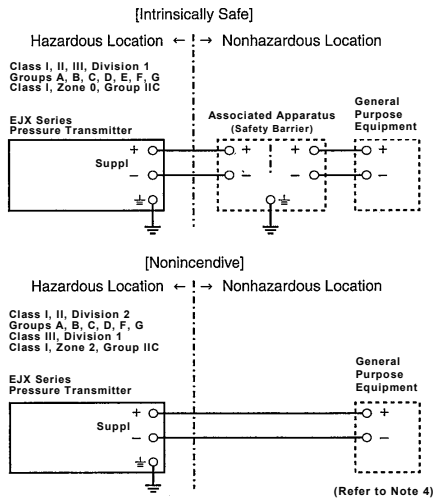

Rev.2: July 16, 2019 Doc. No.: IFM022-A12 P.1
 Yokogawa Electric Corporation

Model: EJX Series Date: October 22, 2003

Specific conditions of use:
 - Precautions shall be taken to minimize the risk from electrostatic discharge of painted parts.
 - When the enclosure of the Pressure Transmitters is made of aluminum alloy, if it is mounted in Zone 0, it must be installed such that, even in the event of rare incidents, an ignition source due to impact and/or friction sparks is excluded.

Entity Parameters [Groups: A, B, C, D, E, F and G]
 Vmax: 30 V
 Imax: 200 mA
 Pmax: 1 W
 Ci: 6 nF
 Li: 0 μH

Entity Parameters [Groups: C, D, E, F and G]
 Vmax: 30 V
 Imax: 225 mA
 Pmax: 1 W
 Ci: 6 nF
 Li: 0 μH

- Notes:
- Installation must be in accordance with the National Electric Code (NFPA70), ANSI/ISA-RP12.06.01, and relevant local codes.
 - The Associated Apparatus must be FM-approved.
 - The following conditions must be satisfied.
 - $V_{oc} \text{ (or } U_o) \leq V_{max}$
 - $I_{sc} \text{ (or } I_o) \leq I_{max}$
 - $P_o \leq P_{max}$
 - $C_a \text{ (or } C_o) \geq C_i + C_{cable}$
 - $L_a \text{ (or } L_o) \geq L_i + L_{cable}$
 - In case Nonincendive Field Wiring Concept is used for the interconnection, FM-approved Associated Nonincendive Field Wiring Apparatus, which meets the above conditions, must be used as the General Purpose Equipment.
 - The General Purpose Equipment connected to the Associated Apparatus must not use or generate a voltage more than U_m of the Associated Apparatus.
 - The control drawing of the Associated Apparatus must be followed when installing the equipment.
 - Dust-tight conduit seals must be used when installed in Class II or Class III environments.
 - WARNING –ELECTROSTATIC CHARGE MAY CAUSE AN EXPLOSION HAZARD. AVOID ANY ACTIONS THAT CAUSE THE GENERATION OF ELECTROSTATIC CHARGE, SUCH AS RUBBING WITH A DRY CLOTH ON COATING FACE OF THE PRODUCT.**
 - WARNING – SUBSTITUTION OF COMPONENTS MAY IMPAIR INTRINSIC SAFETY AND SUITABILITY FOR HAZARDOUS LOCATION**

Rev.3: July 16, 2019 Doc. No.: IFM022-A12 P.2
 Yokogawa Electric Corporation

b. FM Intrinsically Safe/Nonincendive for Fieldbus Type (Except for EJX9□0A)

EJX/EJA-E Series pressure transmitters with optional code /FS15 are applicable for use in hazardous locations.

Note 1.

- Applicable Standard:
 - FM 3600
 - FM 3610
 - FM 3611
 - FM 3810
 - ANSI/ISA-60079-0-2009
 - ANSI/ISA-60079-11-2009
 - ANSI/ISA-60079-27-2006
 - ANSI/UL 121201
 - ANSI/ISA-61010-1
 - NEMA 250
- Rating
 - Intrinsically Safe with Entity/FISCO for Class I, II, III Division 1, Groups A, B, C, D, E, F, G T4 Class I Zone 0 AEx ia IIC T4 Nonincendive field wiring/FNICO for Class I, II Division 2 Groups A, B, C, D, F, G T4 Class III Division 1 T4 Class I, Zone 2 Group IIC T4
- Ambient temperature: -55 to 60 °C
- Enclosure: Type 4X
- Electrical Connection: 1/2 NPT female, M20 female

Note 2. Installation

Installation should be in accordance with Control Drawing IFM024-A12.

Note 3. Specific conditions of use:

Precautions shall be taken to minimize the risk from electrostatic discharge of painted parts. When the enclosure of the Pressure Transmitters is made of aluminum alloy, if it is mounted in Zone 0, it shall be installed such that, even in the event of rare incidents, an ignition source due to impact and/or friction sparks is excluded.

Note 4. Maintenance and Repair

Only personnel authorized by Yokogawa Electric Corporation can repair the equipment.

Model: EJX-F Series Date: January 27, 2005

Control drawing (intrinsic safety)

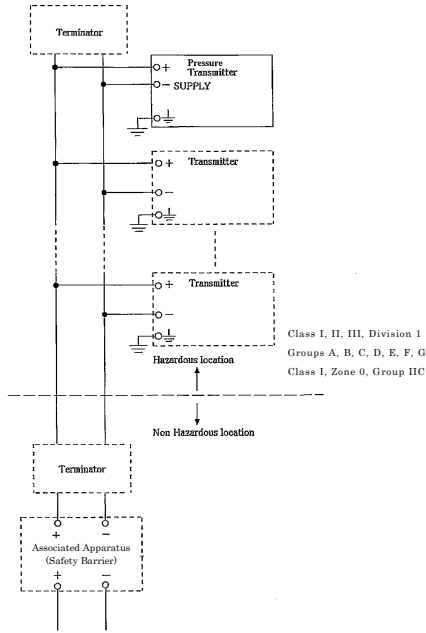

Rev.1: July 16, 2019 Doc. No.: IFM024-A12 P.1

IFM024 Yokogawa Electric Corporation

Model: EJX-F Series Date: January 27, 2005

Specific conditions of use:

- Precautions shall be taken to minimize the risk from electrostatic discharge of painted parts.
- When the enclosure of the Pressure Transmitters is made of aluminum alloy, if it is mounted in Zone 0, it shall be installed such that, even in the event of rare incidents, an ignition source due to impact and/or friction sparks is excluded.

Entity parameters [Groups: A, B, C, D, E, F, G, and IIC]

- Ui: 24 V
- Ii: 250 mA
- Pi: 1.2 W
- Ci: 3.52 nF
- Li: 0 μH

FISCO parameters (1) [Groups: A, B, C, D, E, F, G, and IIC]

- Ui: 17.5 V
- Ii: 380 mA
- Pi: 5.32 W
- Ci: 3.52 nF
- Li: 0 μH

FISCO parameters (2) [Groups: C, D, E, F, G, and IIB]

- Ui: 17.5 V
- Ii: 460 mA
- Pi: 5.32 W
- Ci: 3.52 nF
- Li: 0 μH

Notes:

1. Installation must be in accordance with the National Electric Code (NFPA70), ANSI/ISA-RP12.06.01, and relevant local codes.
2. The Associated Apparatus and the Terminators must be FM-approved.
3. The following conditions must be satisfied.
 - Voc (or Uo) ≤ Ui
 - Isc (or Io) ≤ Ii
 - Po ≤ Pi
 - Ca (or Co) ≥ Ci + Ccable
 - La (or Lo) ≥ Li + Lcable
4. General Purpose Equipment connected to the Associated Apparatus must not use or generate a voltage more than Um of the Associated Apparatus.
5. The control drawing of the Associated Apparatus must be followed when installing the equipment.
6. Dust-tight conduit seals must be used when installed in Class II or Class III environments.
7. WARNING –ELECTROSTATIC CHARGE MAY CAUSE AN EXPLOSION HAZARD. AVOID ANY ACTIONS THAT CAUSE THE GENERATION OF ELECTROSTATIC CHARGE, SUCH AS RUBBING WITH A DRY CLOTH ON COATING FACE OF THE PRODUCT.
8. WARNING – SUBSTITUTION OF COMPONENTS MAY IMPAIR INTRINSIC SAFETY AND SUITABILITY FOR HAZARDOUS LOCATION

Rev.4: July 16, 2019 Doc. No.: IFM024-A12 P.2

IFM024 Yokogawa Electric Corporation

Model: EJX-F Series Date: May 9, 2006

FISCO Rules

The FISCO Concept allows the interconnection of intrinsically safe apparatus to associated apparatus not specifically examined in such combination. The criterion for such interconnection is that the voltage (Ui), the current (Ii) and the power (Pi) which intrinsically safe apparatus can receive and remain intrinsically safe, considering faults, must be equal or greater than the voltage (Uo, Voc or Vt), the current (Io, Isc or It) and the power (Po) which can be provided by the associated apparatus (supply unit). In addition, the maximum unprotected residual capacitance (Ci) and inductance (Li) of each apparatus (other than terminators) connected to the Fieldbus must be less than or equal to 5 nF and 10 μH respectively.

In each I.S. Fieldbus segment only one active source, normally the associated apparatus, is allowed to provide the necessary power for the Fieldbus system. The allowed voltage (Uo, Voc or Vt) of the associated apparatus used to supply the bus cable must be limited to the range of 14 V d.c. to 17.5 V d.c. All other equipment connected to the bus cable has to be passive, meaning that the apparatus is not allowed to provide energy to the system, except a leakage current of 50 μA for each connected device. Separately powered equipment needs galvanic isolation to ensure the intrinsically safe Fieldbus circuit remains passive.

The cable used to interconnect the devices needs to comply with the following parameters:

- Loop resistance R: 15...150 Ω/km
- Inductance per unit length L': 0.4...1 mH/km
- Capacitance per unit length C': 45...200 nF/km C' = C' line/line + 0.5 C' line/screen, if both lines are floating or C' = C' line/line + C' line/screen, if the screen is connected to one line.
- Length of spur cable: max. 60 m
- Length of trunk cable: max. 1 km in IIC and 5 km in IIB
- Length of splice: max = 1 m

Terminators

At the end of each trunk cable an FM Approved line terminator with the following parameters is suitable:

- R = 90...100 Ω
- C = 0...2.2 pF

Rev.1: July 16, 2019 Doc. No.: IFM024-A12 P.2-1

IFM024 Yokogawa Electric Corporation

Model: EJX-F Series Date: January 27, 2005

Control drawing (nonincendive)

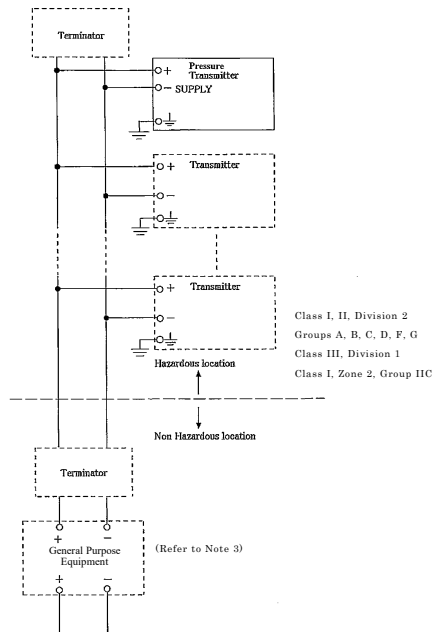

Rev.1: July 16, 2019 Doc. No.: IFM024-A12 P.3

IFM024 Yokogawa Electric Corporation

Model: EJX-F Series Date: January 27, 2005

Nonincendive field wiring parameters
 Vmax: 32 V
 Ci: 3.52 nF
 Li: 0 μH

Notes:

1. Installation must be in accordance with the National Electric Code (NFPA70), ANSI/ISA-RP12.06.01, and relevant local codes.
2. The following conditions must be satisfied.
3. In case Nonincendive Field Wiring Concept is used for the interconnection, FM-approved Associated Nonincendive Field Wiring Apparatus, which meets the following conditions, must be used as the General Purpose Equipment. The Terminators also must be FM approved.
 Voc (or Uo) ≤ Vmax
 Ca (or Co) ≤ Ci + Ccable
 La (or Lo) ≥ Li + Leable
4. Dust-tight conduit seals must be used when installed in Class II or Class III environments.
5. **WARNING – SUBSTITUTION OF COMPONENTS MAY IMPAIR INTRINSIC SAFETY AND SUITABILITY FOR HAZARDOUS LOCATION**

Rev.5: July 16, 2019 Doc. No.: IFM024-A12 P.4-1

IFM024 Yokogawa Electric Corporation

Model: EJX-F Series Date: August 19, 2005

FNICO Rules

The FNICO Concept allows the interconnection of nonincendive field wiring apparatus to associated nonincendive field wiring apparatus not specifically examined in such combination. The criterion for such interconnection is that the voltage (Vmax), the current (Imax) and the power (Pmax), which nonincendive field wiring apparatus can receive and remain nonincendive, must be equal or greater than the voltage (Uo, Voc or Vt), the current (Io, Isc or Ib) and the power (Po) which can be provided by the associated nonincendive field wiring apparatus (supply unit). In addition the maximum unprotected residual capacitance (Ci) and inductance (Li) of each apparatus (other than terminators) connected to the Fieldbus must be less than or equal to 5 nF and 20 μH respectively.

In each N.I. Fieldbus segment only one active source, normally the associated nonincendive field wiring apparatus, is allowed to provide the necessary power for the Fieldbus system. The allowed voltage (Uo, Voc or Vt) of the associated nonincendive field wiring apparatus used to supply the bus cable must be limited to the range 14 V d.c. to 17.5 V d.c. All other equipment connected to the bus cable has to be passive, meaning that the apparatus is not allowed to provide energy to the system, except a leakage current of 50 μA for each connected device. Separately powered equipment needs galvanic isolation to ensure the nonincendive field wiring Fieldbus circuit remains passive. The cable used to interconnect the devices needs to comply with the following parameters:

Loop resistance R: 15...150 Ω/km
 Inductance per unit length L: 0.4...1 mH/km
 Capacitance per unit length C: 45...200 nF/km C' = C' line/line + 0.5 C' line/screen, if both lines are floating or C' = C' line/line + C' line/screen, if the screen is connected to one line.
 Length of spur cable: max. 60 m
 Length of trunk cable: max. 1 km in IIC and 5 km in IIB
 Length of splice: max = 1 m

Terminators
 At the end of each trunk cable an FM Approved line terminator with the following parameters is suitable:
 R = 90...100 Ω
 C = 0...22 pF

Rev.2: July 16, 2019 Doc. No.: IFM024-A12 P.4-2

IFM024 Yokogawa Electric Corporation

c. FM Intrinsically Safe/Nonincendive for Fieldbus Type for EJX9□0A

EJX multivariable transmitter with optional code /FS15 are applicable for use in hazardous locations.

Note 1.

- Applicable Standard:
 FM 3600:2011
 FM 3610:2010
 FM 3611:2004
 FM 3810:2005
 ANSI/ISA-60079-0-2009
 ANSI/ISA-60079-11-2009
 ANSI/ISA-60079-27-2006
 ANSI/ISA-61010-1-2004
 NEMA 250:1991
- Rating
 Intrinsically Safe with Entity/FISCO for Class I, II, III
 Division 1 Groups A, B, C, D, E, F, G T4
 Class I Zone 0 AEx ia IIC T4
 Nonincendive field wiring/FNICO for Class I, II
 Division 2 Groups A, B, C, D, F, G T4
 Class III Division 1 T4
 Class I, Zone 2 Group IIC T4
- Ambient temperature: -40 to 60°C
- Enclosure: Type 4X
- Electrical Connection: 1/2 NPT female, M20 female

Note 2. Installation

Installation should be in accordance with Control Drawing IFM026-A12.

Note 3. Specific conditions of use:

Precautions shall be taken to minimize the risk from electrostatic discharge of painted parts.
 When the enclosure of the Pressure Transmitters is made of aluminum alloy, if it is mounted in Zone 0, it shall be installed such that, even in the event of rare incidents, an ignition source due to impact and/or friction sparks is excluded.

Model: EJX910A-F Series Date: September 9, 2005

Control drawing (intrinsic safety)

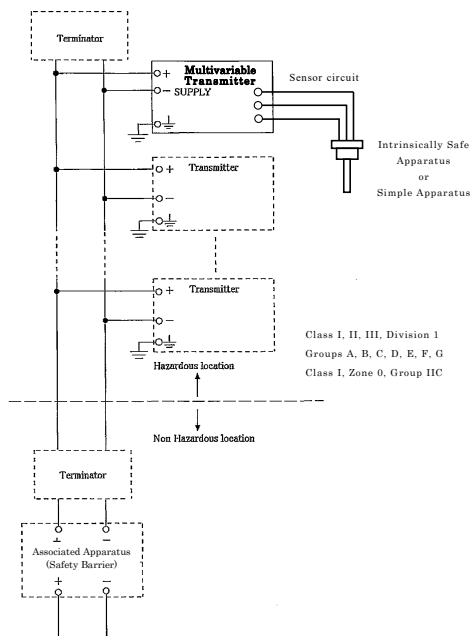

Rev.1: July 16, 2019 Doc. No.: IFM026-A12 P.1

IFM026

Yokogawa Electric Corporation

Model: EJX910A-F Series Date: September 9, 2005

Notes:

1. Installation must be in accordance with the National Electric Code (NFPA70), ANSI/ISA-RP12.06.01, and relevant local codes.
2. The Associated Apparatus and the Terminators must be FM-approved.
3. The following conditions must be satisfied.
 - U_o (or Voc) ≤ U_i (or Vmax)
 - I_o (or Isc) ≤ I_i (or Imax)
 - P_o ≤ P_i
 - C_o (or Ca) ≥ C_i + C_{leable}
 - L_o (or La) ≥ L_i + L_{leable}
4. General Purpose Equipment connected to the Associated Apparatus must not use or generate a voltage more than U_m of the Associated Apparatus.
5. The control drawing of the Associated Apparatus must be followed when installing the equipment.
6. Dust-tight conduit seals must be used when installed in Class II or Class III environments.
7. WARNING –ELECTROSTATIC CHARGE MAY CAUSE AN EXPLOSION HAZARD. AVOID ANY ACTIONS THAT CAUSE THE GENERATION OF ELECTROSTATIC CHARGE, SUCH AS RUBBING WITH A DRY CLOTH ON COATING FACE OF THE PRODUCT.
8. WARNING – SUBSTITUTION OF COMPONENTS MAY IMPAIR INTRINSIC SAFETY AND SUITABILITY FOR HAZARDOUS LOCATION

FISCO Rules

The FISCO Concept allows the interconnection of intrinsically safe apparatus to associated apparatus not specifically examined in such combination. The criterion for such interconnection is that the voltage (U_i), the current (I_i) and the power (P_i) which intrinsically safe apparatus can receive and remain intrinsically safe, considering faults, must be equal or greater than the voltage (U_o, Voc or Vt), the current (I_o, Isc or It) and the power (P_o) which can be provided by the associated apparatus (supply unit). In addition, the maximum unprotected residual capacitance (C) and inductance (L) of each apparatus (other than terminators) connected to the Fieldbus must be less than or equal to 5 nF and 10 μH respectively.

In each I.S. Fieldbus segment only one active source, normally the associated apparatus, is allowed to provide the necessary power for the Fieldbus system. The allowed voltage (U_o, Voc or Vt) of the associated apparatus used to supply the bus cable must be limited to the range of 14 V d.c. to 17.5 V d.c. All other equipment connected to the bus cable has to be passive, meaning that the apparatus is not allowed to provide energy to the system, except a leakage current of 50 μA for each connected device. Separately powered equipment needs galvanic isolation to ensure the intrinsically safe Fieldbus circuit remains passive.

The cable used to interconnect the devices needs to comply with the following parameters:

- Loop resistance R: 15...150 Ω/km
- Inductance per unit length L: 0.4...1 mH/km
- Capacitance per unit length C: 45...200 nF/km C' = C' line/line + 0.5 C' line/screen, if both lines are floating or C' = C' line/line + C' line/screen, if the screen is connected to one line.
- Length of spur cable: max. 60 m
- Length of trunk cable: max. 1 km in IIC and 5 km in IIB
- Length of splice: max = 1 m

Terminators
At the end of each trunk cable an FM Approved line terminator with the following parameters is suitable:

- R = 90...100 Ω
- C = 0...2.2 μF

Rev.2: July 16, 2019 Doc. No.: IFM026-A12 P.3

IFM026

Yokogawa Electric Corporation

Model: EJX910A-F Series Date: September 9, 2005

Specific conditions of use:

- Precautions shall be taken to minimize the risk from electrostatic discharge of painted parts.
- When the enclosure of the Pressure Transmitters is made of aluminum alloy, if it is mounted in Zone 0, it shall be installed such that, even in the event of rare incidents, an ignition source due to impact and/or friction sparks is excluded.

Supply circuit:

Entity parameters [Groups: A, B, C, D, E, F, G, and IIC]

- U_i: 24 V
- I_i: 250 mA
- P_i: 1.2 W
- C_i: 3.52 nF
- L_i: 0 μH

FISCO parameters (1) [Groups: A, B, C, D, E, F, G, and IIC]

- U_i: 17.5 V
- I_i: 380 mA
- P_i: 5.32 W
- C_i: 3.52 nF
- L_i: 0 μH

FISCO parameters (2) [Groups: C, D, E, F, G, and IIB]

- U_i: 17.5 V
- I_i: 400 mA
- P_i: 5.32 W
- C_i: 3.52 nF
- L_i: 0 μH

Sensor circuit:

Entity parameters [Groups: A, B, C, D, E, F, G, and IIC]

- U_o: 6.51 V
- I_o: 4 mA
- P_o: 6 mW
- C_o: 34 μF
- L_o: 500 mH

Rev.2: July 16, 2019 Doc. No.: IFM026-A12 P.2

IFM026

Yokogawa Electric Corporation

Model: EJX910A-F Series Date: May 22, 2006

Control drawing (nonincendive)

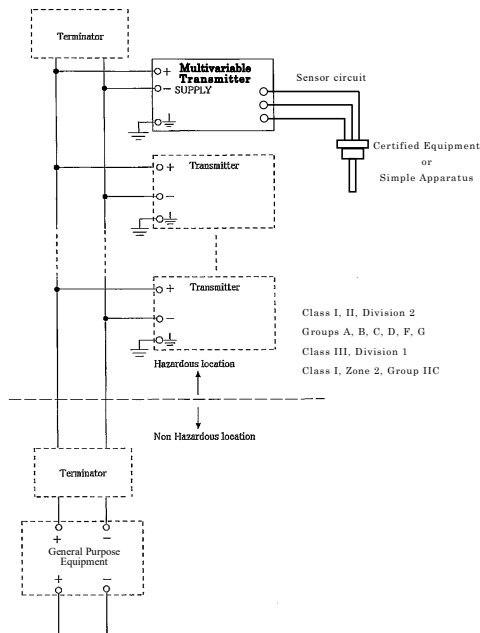

Rev.1: July 16, 2019 Doc. No.: IFM026-A12 P.3-1

IFM026

Yokogawa Electric Corporation

Model: EJX910A-F Series Date: May 22, 2006

Nonincendive field wiring parameters

Supply circuit:
 Vmax: 32 V
 Ci: 3.52 nF
 Li: 0 μH

Sensor circuit:
 Vi: 6 V
 Ii: 25 mA
 Po: 0.15 W
 Ca: 40 μF
 La: 40 mH

Notes:

1. Installation must be in accordance with the National Electric Code (NFPA70), ANSI/ISA-RP12.06.01, and relevant local codes.
2. The following conditions must be satisfied.
3. In case Nonincendive Field Wiring Concept is used for the interconnection, FM-approved Associated Nonincendive Field Wiring Apparatus, which meets the following conditions, must be used as the General Purpose Equipment. The Terminators also must be FM approved.
 - Uo (or Voc) ≤ Ui (or Vmax)
 - Io (or Isc) ≤ Ii (or Imax)
 - Po ≤ Pi
 - Co (or Ca) ≥ Ci + Ccable
 - Lo (or La) ≥ Li + Lcable
4. WARNING – SUBSTITUTION OF COMPONENTS MAY IMPAIR INTRINSIC SAFETY AND SUITABILITY FOR HAZARDOUS LOCATION

Dust-tight conduit seals must be used when installed in Class II or Class III environments.

Rev.3: July 16, 2019 Doc. No.: IFM026-A12 P.3-2

Yokogawa Electric Corporation
 IFM026

Model: EJX910A-F Series Date: May 22, 2006

FNICO Rules

The FNICO Concept allows the interconnection of nonincendive field wiring apparatus to associated nonincendive field wiring apparatus not specifically examined in such combination. The criterion for such interconnection is that the voltage (Vmax), the current (Imax) and the power (Pmax), which nonincendive field wiring apparatus can receive and remain nonincendive, must be equal or greater than the voltage (Uo, Voc or Vd), the current (Io, Isc or Id) and the power (Po) which can be provided by the associated nonincendive field wiring apparatus (supply unit). In addition the maximum unprotected residual capacitance (Ci) and inductance (Li) of each apparatus (other than terminators) connected to the Fieldbus must be less than or equal to 5 nF and 20 μH respectively.

In each N.I. Fieldbus segment only one active source, normally the associated nonincendive field wiring apparatus, is allowed to provide the necessary power for the Fieldbus system. The allowed voltage (Uo, Voc or Vd) of the associated nonincendive field wiring apparatus used to supply the bus cable must be limited to the range 14 V d.c. to 17.5 V d.c. All other equipment connected to the bus cable has to be passive, meaning that the apparatus is not allowed to provide energy to the system, except a leakage current of 50 μA for each connected device. Separately powered equipment needs galvanic isolation to ensure the nonincendive field wiring Fieldbus circuit remains passive. The cable used to interconnect the devices needs to comply with the following parameters:

- Loop resistance R: 15...150 Ω/km
- Inductance per unit length L: 0.4...1 mH/km
- Capacitance per unit length C: 45...300 nF/km C' = C' line/line + 0.5 C' line/screen, if both lines are floating or C' = C' line/line + C' line/screen, if the screen is connected to one line.
- Length of spur cable: max. 60 m
- Length of trunk cable: max. 1 km in IIC and 5 km in IIB
- Length of splice: max = 1 m
- Terminators
- At the end of each trunk cable an FM Approved line terminator with the following parameters is suitable:
 - R = 90...100 Ω
 - C = 0...2.2 pF

Rev.1: July 16, 2019 Doc. No.: IFM026-A12 P.3-3

Yokogawa Electric Corporation
 IFM026

d. FM Explosionproof

Caution for FM explosionproof type.

Note 1. EJX/EJA-E Series pressure transmitters with optional code /FF1 or /V1F are applicable for use in hazardous locations.

- Applicable Standard: FM3600:2018, FM3615:2018, FM3810:2018, NEMA 250:2003, ANSI/UL 61010-1:2012, ANSI/UL 61010-2-30:2012
- Explosionproof for Class I, Division 1, Groups B, C and D.
- Dust-ignitionproof for Class II/III, Division 1, Groups E, F and G.
- Enclosure: Type 4X
- Temperature Class: T6
- Ambient Temperature: -40 to 60°C
- Supply Voltage: 42 V dc max. 32 V dc max. (FOUNDATION Fieldbus and PROFIBUS PA type) 9 to 28 V dc, 27 mW (Low Power type) 9 to 30 V dc, 250 mW (RS485 Modbus Communication Type)
- Output signal: 4 to 20 mA 15 mA (FOUNDATION Fieldbus and PROFIBUS PA type) 1 to 5 V (Low Power type) RS485 Modbus (RS485 Modbus Communication Type)

Note 2. Wiring

- All wiring shall comply with National Electrical Code ANSI/NFPA70 and Local Electrical Codes.
- When installed in Division 1, "FACTORY SEALED, CONDUIT SEAL NOT REQUIRED."
- Wiring connection for output signal code Q (Low Power type) shall follow the diagram below.

Pressure Transmitters

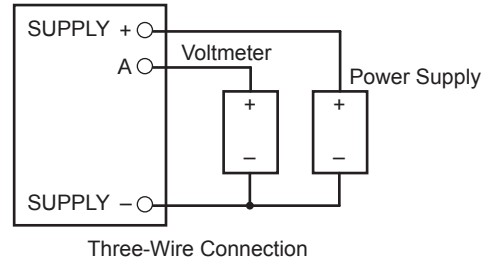

Pressure Transmitters

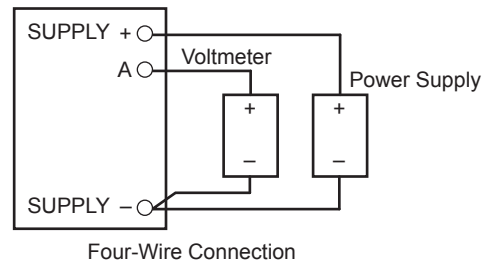

F0218.ai

Note 3. Operation

- Keep the "WARNING" nameplate attached to the transmitter.
WARNING: OPEN CIRCUIT BEFORE REMOVING COVER. FACTORY SEALED, CONDUIT SEAL NOT REQUIRED. INSTALL IN ACCORDANCE WITH THE USERS MANUAL IM 01C25.
- Take care not to generate mechanical sparking when accessing to the instrument and peripheral devices in a hazardous location.

Note 4. Maintenance and Repair

- The instrument modification or parts replacement by other than authorized representative of Yokogawa Electric Corporation is prohibited and will void Factory Mutual Explosionproof Approval.

e. FM Intrinsically Safe and Explosion Proof Combination for HART/BRAIN Protocol Type

EJX/EJA-E Series pressure transmitters with optional code /FU1 or /V1U1 can be selected the type of protection (FM Intrinsically Safe or FM Explosionproof) for use in hazardous locations.

Note 1. For the installation of this transmitter, once a particular type of protection is selected, any other type of protection cannot be used. The installation must be in accordance with the description about the type of protection in this instruction manual.

Note 2. In order to avoid confusion, unnecessary marking is crossed out on the label other than the selected type of protection when the transmitter is installed.

2.4.2 CSA Certification

a. CSA Intrinsically Safe for HART/BRAIN Protocol Type (Except for EJX9□0A)

Caution for CSA Intrinsically safe and nonincendive type. (Following contents refer to "DOC No. ICS013-A13")

Note 1. EJX/EJA-E Series pressure transmitters with optional code /CS1 are applicable for use in hazardous locations.

- Certificate: 1606623
- Applicable Standard:
CAN/CSA C22.2 No.0
CSA C22.2 No.94.2
CSA C22.2 No.213

- CAN/CSA C22.2 No.61010-1
- CAN/CSA C22.2 No.61010-2-030
- CAN/CSA C22.2 No.60079-0
- CAN/CSA C22.2 No.60079-11
- CAN/CSA E60079-15
- CAN/CSA C22.2 No.60529
- ANSI/ISA-12.27.01

[For Division system]

- Intrinsically Safe for Class I, Division 1, Groups A, B, C & D, Class II, Division 1, Groups E, F & G, Class III, Division 1
- Nonincendive for Class I, Division 2, Groups A, B, C & D, Class II, Division 2, Groups F & G, Class III, Division 1
- Enclosure: Type 4X
- Temp. Code: T4
- Amb. Temp.: -50* to 60°C
* -15°C when /HE is specified.
- Process Temperature: 120°C max.

[For Zone system]

- Ex ia IIC T4, Ex nL IIC T4
- Ambient Temperature: -50 to 60°C
- Max. Process Temp.: 120°C
- Enclosure: IP66/IP67

Note 2. Entity Parameters

- Intrinsically safe ratings are as follows:
Maximum Input Voltage (Vmax/Ui) = 30 V
Maximum Input Current (Imax/Ii) = 200 mA
Maximum Input Power (Pmax/Pi) = 0.9 W
Maximum Internal Capacitance (Ci) = 10 nF
Maximum Internal Inductance (Li) = 0 μH
- Type "n" or Nonincendive ratings are as follows:
Maximum Input Voltage (Vmax/Ui) = 30 V
Maximum Internal Capacitance (Ci) = 10 nF
Maximum Internal Inductance (Li) = 0 μH
- Installation Requirements
Uo ≤ Ui, Io ≤ Ii, Po ≤ Pi,
Co ≥ Ci + Ccable, Lo ≥ Li + Lcable
Voc ≤ Vmax, Isc ≤ Imax,
Ca ≥ Ci + Ccable, La ≥ Li + Lcable
Uo, Io, Po, Co, Lo, Voc, Isc, Ca and La are parameters of barrier.

Note 3. Installation

- In any safety barrier used output current must be limited by a resistor 'R' such that Io=Uo/R or Isc=Voc/R.
- The safety barrier must be CSA certified.
- Input voltage of the safety barrier must be less than 250 Vrms/Vdc.
- Installation should be in accordance with Canadian Electrical Code Part I and Local Electrical Code.
- Dust-tight conduit seal must be used when installed in Class II and III environments.

- The instrument modification or parts replacement by other than authorized representative of Yokogawa Electric Corporation and Yokogawa Corporation of America is prohibited and will void Canadian Standards Intrinsically safe and nonincendive Certification.

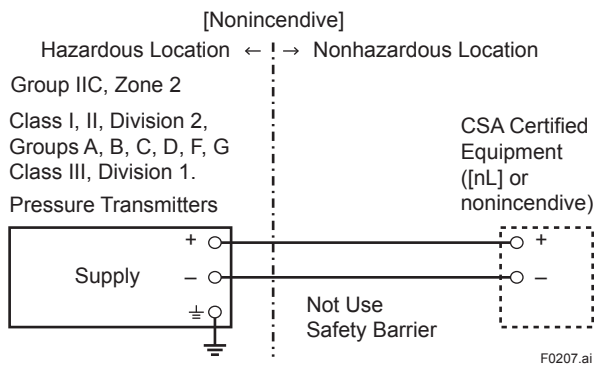
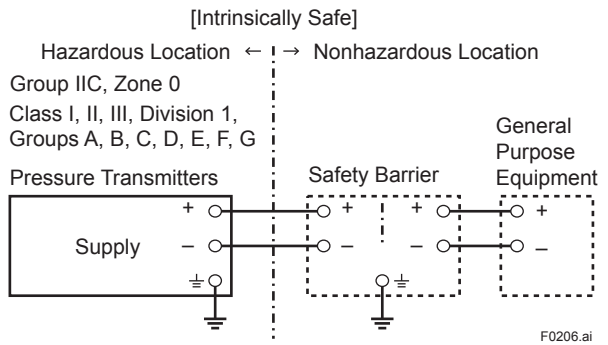

b. CSA Intrinsically Safe for Fieldbus Type (Except for EJX9□0A)

EJX/EJA-E Series pressure transmitters with optional code /CS15 are applicable for use in hazardous locations.

- Certificate: 1689689
- Applicable standard:
CAN/CSA C22.2 No.0
CSA C22.2 No.94.2
CSA C22.2 No.213
CAN/CSA C22.2 No.61010-1
CAN/CSA C22.2 No.61010-2-030
CAN/CSA C22.2 No.60079-0
CAN/CSA C22.2 No.60079-11
CAN/CSA E60079-15
CAN/CSA C22.2 No.60529
ANSI/ISA-12.27.01

- CSA Intrinsically Safe Approval
Class I, Division 1, Groups A, B, C, & D;
Class II, Division 1, Groups E, F & G;
Class III, Division 1; Ex ia IIB/IIC T4
Ambient Temperature: -55* to 60 °C
* -15°C when /HE is specified.
Type 4X, IP66/IP67
- CSA Nonincendive Approval
Class I, Division 2, Groups A, B, C, & D;
Class II, Division 2, Groups F & G;
Class III, Division 1; Ex nL IIC T4
Ambient Temperature: -55* to 60 °C
* -15°C when /HE is specified.
Type 4X, IP66/ IP67

● **Caution for CSA Intrinsically Safe Type. (Following Contents Refer to “DOC. No. ICS018)**

Installation Diagram for Intrinsically Safe (Division 1 Installation)

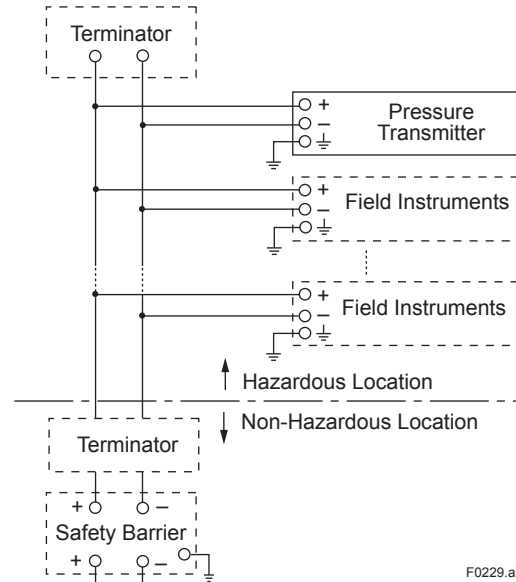

- Note 1. The safety barrier must be CSA certified.
- Note 2. Input voltage of the safety barrier must be less than 250Vrms/Vdc.
- Note 3. Installation should be in accordance with Canadian Electrical Code Part I and local Electrical Code.
- Note 4. Do not alter drawing without authorization from CSA.

Electrical Data:

- Rating 1 (Entity)
 For Groups A, B, C, D, E, F, and G or Group IIC
 $U_i (v_{max}) = 24 \text{ V dc}$
 $I_i (I_{max}) = 250 \text{ mA}$
 $P_i (P_{max}) = 1.2 \text{ W}$
 $C_i = 3.52 \text{ nF}$
 $L_i = 0 \text{ } \mu\text{H}$

or

- Rating 2 (FISCO)
 For Groups A, B, C, D, E, F, and G or Group IIC
 $U_i (v_{max}) = 17.5 \text{ V dc}$
 $I_i (I_{max}) = 380 \text{ mA}$
 $P_i (P_{max}) = 5.32 \text{ W}$
 $C_i = 3.52 \text{ nF}$
 $L_i = 0 \text{ } \mu\text{H}$

or

- Rating 3 (FISCO)
 For Groups C, D, E, F, and G or Group IIB
 $U_i (v_{max}) = 17.5 \text{ V dc}$
 $I_i (I_{max}) = 460 \text{ mA}$
 $P_i (P_{max}) = 5.32 \text{ W}$
 $C_i = 3.52 \text{ nF}$
 $L_i = 0 \text{ } \mu\text{H}$

Installation requirements:

- $P_o \leq P_i$ $U_o \leq U_i$ $I_o \leq I_i$,
 - $C_o \geq C_i + C_{cable}$ $L_o \geq L_i + L_{cable}$
 - $V_{max} \geq V_{oc}$ $I_{max} \geq I_{sc}$
 - $C_a \geq C_i + C_{cable}$ $L_a \geq L_i + L_{cable}$
- $U_o, I_o, P_o, C_o, L_o, V_{oc}, I_{sc}, C_a$ and L_a are parameters of barrier.

- **Caution for CSA Non-incendive Type.**
 (Following contents refer to “DOC. No. ICS018)

Installation Diagram for Non-incendive or Type of protection “n” (Division 2 Installation)

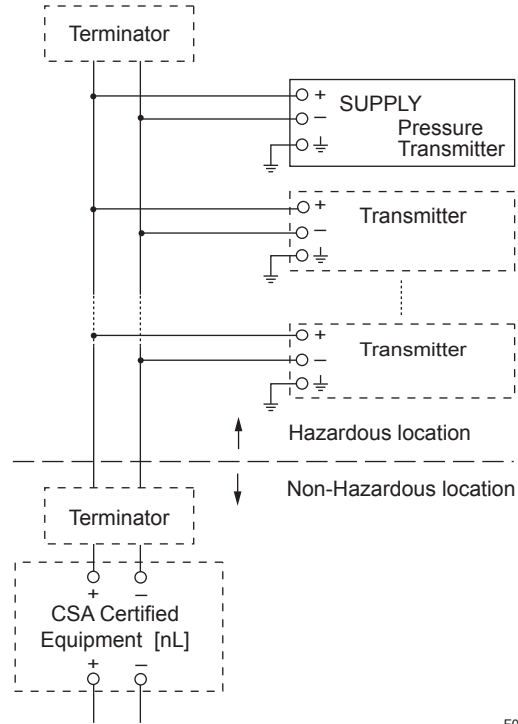

F0230.ai

- Note 1. Installation should be in accordance with Canadian Electrical Code Part I and local Electrical Code.
- Note 2. Dust-tight conduit seal must be used when installed in class II and III environments.
- Note 3. Do not alter drawing without authorization from CSA.

Electrical Data:

- Rating (including FNICO)
 U_i or $V_{max} = 32 \text{ V}$
 $C_i = 3.52 \text{ nF}$
 $L_i = 0 \text{ } \mu\text{H}$

c. CSA Explosionproof Type

Caution for CSA explosionproof type.

Note 1. EJX/EJA-E Series pressure transmitters with optional code /CF1 or /V1F are applicable for use in hazardous locations.

- Certificate: 2014354
- Applicable Standard:
 - C22.2 No. 25
 - C22.2 No. 30
 - CAN/CSA-C22.2 No. 94
 - CAN/CSA-C22.2 No. 61010-1-12
 - CAN/CSA-C22.2 No. 61010-2-030-12
 - CAN/CSA-C22.2 No. 60079-0:07
 - CAN/CSA-C22.2 No. 60079-1:07
 - CAN/CSA-C22.2 No. 60529
 - ANSI/ISA-12.27.01
- Explosion-proof for Class I, Groups B, C and D.
- Dustignition-proof for Class II/III, Groups E, F and G.
- Enclosure: Type 4X
- Temperature Code: T6...T4
- Ex d IIC T6...T4
- Enclosure: IP66/IP67
- Maximum Process Temperature: 120°C (T4), 100°C (T5), 85°C (T6)
- Ambient Temperature: -50* to 75°C (T4), -50* to 80°C (T5), -50* to 75°C (T6)
* -15°C when /HE is specified.
- Supply Voltage: 42 V dc max.
32 V dc max. (FOUNDATION Fieldbus and PROFIBUS PA type)
9 to 28 V dc, 27 mW (Low Power type)
9 to 30 V dc, 250 mW (RS485 Modbus Communication Type)
- Output Signal: 4 to 20 mA dc
15 mA (FOUNDATION Fieldbus and PROFIBUS PA type)
1 to 5 V (Low Power type)
RS485 Modbus (RS485 Modbus Communication Type)

Note 2. Wiring

- All wiring shall comply with Canadian Electrical Code Part I and Local Electrical Codes.
- In hazardous location, wiring shall be in conduit as shown in the figure.
- WARNING:
A SEAL SHALL BE INSTALLED WITHIN 45cm OF THE ENCLOSURE.
UN SCELEMENT DOIT ÊTRE INSTALLÉ À MOINS DE 45cm DU BOÎTIER.
- WARNING:
WHEN INSTALLED IN CL.I, DIV 2, SEAL NOT REQUIRED.
UNE FOIS INSTALLÉ DANS CL I, DIV 2, AUCUN JOINT N'EST REQUIS.

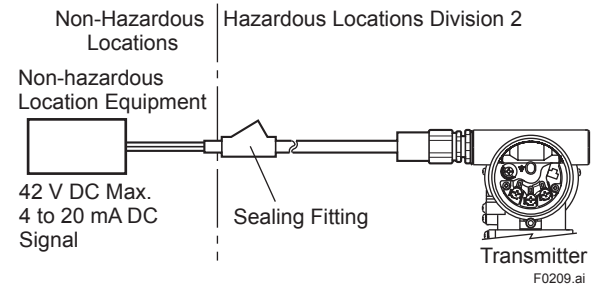
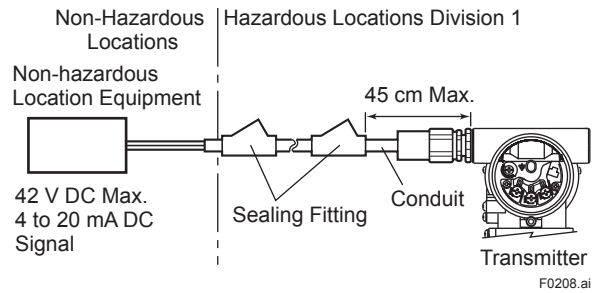

- All wiring shall comply with local installation requirements and local electrical code.
- In hazardous locations, the cable entry devices shall be of a certified flameproof type, suitable for the conditions of use and correctly installed.
- Unused apertures shall be closed with suitable flameproof certified blanking elements. (The plug attached is flameproof certified.)
- Wiring connection for output signal code Q (Low Power type) shall follow the diagram below.

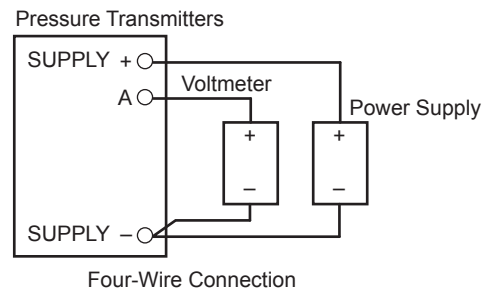
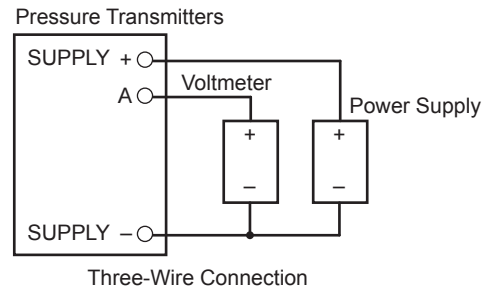

F0219.ai

Note 3. Operation

- WARNING:
AFTER DE-ENERGIZING, DELAY 5 MINUTES BEFORE OPENING.
APRÉS POWER-OFF, ATTENDRE 5 MINUTES AVANT D'OUVRIR.
- WARNING:
WHEN AMBIENT TEMPERATURE ≥ 65°C, USE THE HEAT-RESISTING CABLES ≥ 90°C.
QUAND LA TEMPÉRATURE AMBIANTE ≥ 65°C, UTILISEZ DES CÂBLES RÉSIANTES À LA CHALEUR ≥ 90°C.
- Take care not to generate mechanical sparking when accessing to the instrument and peripheral devices in a hazardous location.

Note 4. Maintenance and Repair

- The instrument modification or parts replacement by other than authorized representative of Yokogawa Electric Corporation and Yokogawa Corporation of America is prohibited and will void Canadian Standards Explosionproof Certification.

d. CSA Intrinsically Safe and Explosion-proof Combination for HART/BRAIN Protocol Type (Except for EJX9□0A)

EJX/EJA-E Series pressure transmitters with optional code /CU1 or /V1U1 can be selected the type of protection (CSA Intrinsically Safe or CSA Explosionproof) for use in hazardous locations.

Note 1. For the installation of this transmitter, once a particular type of protection is selected, any other type of protection cannot be used. The installation must be in accordance with the description about the type of protection in this instruction manual.

Note 2. For combined approval types, once a device of multiple approval type is installed, it should not be re-installed using any other approval types. Apply a permanent mark in the check box of the selected approval type on the certification label on the transmitter to distinguish it from unused approval types.

2.4.3 ATEX Certification

(1) Technical Data

a. ATEX Intrinsically Safe for HART/BRAIN Protocol Type (Except for EJX9□0A)

Caution for ATEX Intrinsically safe type.

Note 1. EJX/EJA-E Series pressure transmitters with optional code /KS21 for potentially explosive atmospheres.

- Applicable standards:
EN IEC 60079-0, EN 60079-11
- Certificate number: DEKRA 11ATEX0228 X
- Specific Ex marking:

	II 1 G	<input type="checkbox"/>	Ex ia IIC T4 Ga
	II 2 D	<input type="checkbox"/>	Ex ia IIIC T85°C T100°C T120°C Db

- Ambient temperature:
EPL Ga -50°C ≤ Ta ≤ +60°C
EPL Db -30°C ≤ Ta ≤ +60°C
EPL Db * -15°C ≤ Ta ≤ +60°C

- Process temperature:
EPL Ga -50°C ≤ Tp ≤ +120°C
EPL Db T120°C -30°C ≤ Tp ≤ +120°C
T100°C -30°C ≤ Tp ≤ +100°C
T85°C -30°C ≤ Tp ≤ +80°C
EPL Db * T120°C -15°C ≤ Tp ≤ +120°C
T100°C -15°C ≤ Tp ≤ +100°C
T85°C -15°C ≤ Tp ≤ +80°C

* When FKM O-rings are used. (/HE is specified.)

- Enclosure:
IP66/IP67 in accordance with EN IEC 60079-0
- Power supply: ≤ 30 V, ≤ 21.6 mA
- Dielectric strength:
500 V AC, r.m.s., 1 min Terminals: to Enclosure
Supply +
Supply -

Note 2. Specific condition of use

When the equipment is mounted in an area where the use of Category 1 G equipment is required, it shall be installed in such a way that, even in the event of rare incidents, an ignition source due to impact and/or friction sparks is excluded.

Precaution shall be taken to minimize the risk from electrostatic discharges or propagating brush discharges on the non-metallic parts (excluding glass parts) or coated parts of the equipment.

The dielectric strength of at least 500 V of the intrinsically safe circuits of the equipment is limited only by the overvoltage protection. From the safety point of view, the intrinsically safe circuit of the equipment shall be assumed to be connected to earth.

Note 3. Installation and erection

Cable entry devices suitable for the thread form and the size of the cable entries must be used, according to the following marking on the equipment.

Screw Size	Marking
ISO M20 × 1.5 female	△ M
ANSI 1/2 NPT female	△ A or △ N or △ W

F0239.ai

When installing the equipment, the selected Type of Protection should be ticked as follows.

- Ex ia IIC T4 Ga
 - Ex ia IIIC T85°C T100°C T120°C Db
- See the control drawing.

Note 4. Use and setting-up (operation)

If the equipment is mounted in an area where explosive atmospheres may be present, it must be installed in such a way that the risk from electrostatic discharges and propagating brush discharges caused by rapid flow of dust are avoided.

Note 5. Maintenance and repair



WARNING

A modification of the equipment would no longer comply with the construction described in the certificate documentation.

Only personnel authorized by Yokogawa Electric Corporation can repair the equipment.

Yokogawa Electric Corporation		Model	EJX Series				
Title	Control drawing (General)						
No.	IKE045-A91	Page	1	Revision	0	Date	2020-08-07

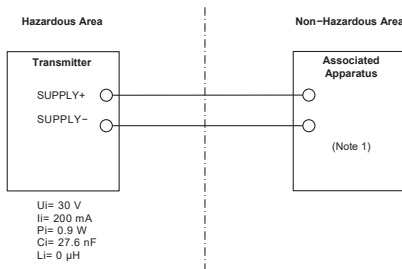

Notes:
1. Associated Apparatus must be a linear power source whose output current is resistively limited.

b. ATEX Intrinsically Safe for Fieldbus Type (Except for EJX9□0A)

Caution for ATEX Intrinsically safe type.

Note 1. EJX/EJA-E series pressure transmitters with optional code /KS26 for potentially explosive atmospheres:

Certification Information:



WARNING

A modification of the equipment would no longer comply with the construction described in the certificate documentation.

Certificate Number:
KEMA 04ATEX1116 X



NOTE

The symbol "X" placed after the certificate number indicates that the equipment is subject to specific conditions of use.

Applicable Standard:
EN IEC 60079-0
EN 60079-11

Note 2. Rating

Ex Marking:

II 2 G Ex ia IIC/IIB T4 Ga
II 2 D Ex ia IIIC T85°C T100°C T120°C Db

Temperature Specifications:

Ambient Temperature range and Process
Temperature range for Gas:

Ambient temperature range	Process temperature range
-55 to 60°C	-55 to 120°C

Ambient Temperature range and Process
Temperature range for Dust:

Maximum surface temperature	Ambient temperature range	Process temperature range	Type of O-ring
T85°C	-30 to 60°C	-30 to 80°C	NBR
	-15 to 60°C	-15 to 80°C	Fluoro-rubber(FKM)
T100°C	-30 to 60°C	-30 to 100°C	NBR
	-15 to 60°C	-15 to 100°C	Fluoro-rubber(FKM)
T120°C	-30 to 60°C	-30 to 120°C	NBR
	-15 to 60°C	-15 to 120°C	Fluoro-rubber(FKM)

Enclosure:
IP66/IP67 in accordance with only EN60529
Electrical Parameters:
Intrinsically safe ratings are as follows:

[Entity]
U_i = 24 V
I_i = 250 mA
P_i = 1.2 W
C_i = 3.52 nF
L_i = 0 μH

[FISCO IIC]
U_i = 17.5 V
I_i = 380 mA
P_i = 5.32 W
C_i = 3.52 nF
L_i = 0 μH

[FISCO IIB]
U_i = 17.5 V
I_i = 460 mA
P_i = 5.32 W
C_i = 3.52 nF
L_i = 0 μH

Note 3. Installation:

- Refer to the control drawing IKE022-A12 P.1 and P.2. (Note 7.)
- The type of threads is indicated at the cable entry, using the following marking.

Screw Size	Marking
ISO M20 × 1.5 female	△ M
ANSI 1/2 NPT female	△ A or △ N or △ W

F0239.ai

- The selected type of the Ex marking on the name plate should be indicated. For this purpose, the tick boxes can be used as follows.
 Ex ia IIC/IIB T4 Ga
 Ex ia IIIC T85°C T100°C T120°C Db

Note 4. Operation:

- If the pressure transmitter is mounted in an area where explosive atmospheres may be present, it must be installed in such a way that the risk from electrostatic discharges and propagating brush discharges caused by rapid flow of dust are avoided.

Note 5. Specific conditions of use:

- When the enclosure of the pressure transmitter is made of aluminum alloy, if it is mounted in an area where the use of Category 1 G equipment is required, it shall be installed such that, even in the event of rare incidents, an ignition source due to impact and friction sparks is excluded.
- Precautions shall be taken to minimize the risk from electrostatic discharge of painted parts.
- The dielectric strength of at least 500 V of the intrinsically safe circuits of the pressure transmitter is limited only by the overvoltage protection.

Note 6. Maintenance and Repair:

- Only personnel authorized by Yokogawa Electric Corporation can repair the equipment.

Note 7. Control drawing

Model: EJX Series Date: March 31, 2004
11.0 Drawings
11.1 Installation Diagram

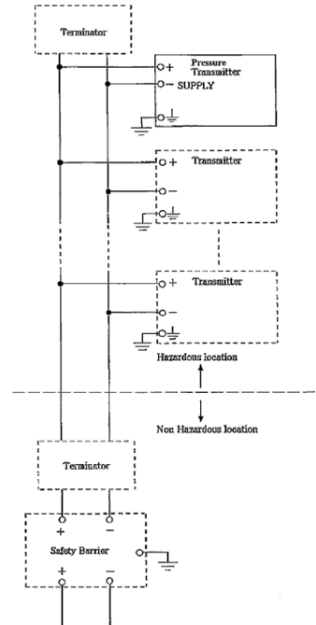

Rev. Doc. No.: IKE022-A12 P.1
Drawing: Y. Takamuku
Approved: K. Masuki

Model: EJX Series Date: March 31, 2004

Note

- In the rating 1(*1), the output current of the barrier must be limited by a resistor 'Ra' such that I_o=U_o/R_a.
- In the rating 2(*2), the output of the barrier must be the characteristics of the trapezoid or the rectangle and this transmitter can be connected to Fieldbus equipment which are in according to the FISCO model.
- The terminators may be built in by a barrier.
- More than one transmitter may be connected to the power supply line.
- The terminator and the safety barrier shall be certified.

Electrical data:

Maximum Input Voltage U _i : 24V	} *1: Rating 1
Maximum Input Current I _i : 250mA	
Maximum Input Power P _i : 1.2W	
Maximum Internal Capacitance C _i : 3.52nF △	
Maximum Internal Inductance L _i : 0 μH	
or	
Maximum Input Voltage U _i : 17.5V	} *2: Rating 2
Maximum Input Current I _i : 380mA △	
Maximum Input Power P _i : 5.32W △	
Maximum Internal Capacitance C _i : 3.52nF △	
Maximum Internal Inductance L _i : 0 μH	
or	
Maximum Input Voltage U _i : 17.5V	
Maximum Input Current I _i : 460mA	
Maximum Input Power P _i : 5.32W	
Maximum Internal Capacitance C _i : 3.52nF △	
Maximum Internal Inductance L _i : 0 μH	

Rev. Δ July 16, 2004 Y. Takamuku Doc. No.: IKE022-A12 P.2
Rev. 2: October 15, 2011 A. Okada Drawing: Y. Takamuku
Approved: K. Masuki

c. ATEX Intrinsically Safe for Fieldbus Type for EJX9□0A

Caution for ATEX Intrinsically safe type.

Note 1. EJX multivariable transmitter with optional code /KS26 are applicable for use in hazardous locations:

- Applicable standards:
EN IEC 60079-0, EN 60079-11
- Certificate number: KEMA 06ATEX0278 X
- Specific Ex marking:

⊕	II 1 G	<input type="checkbox"/> Ex ia IIC/IIB T4 Ga
⊕	II 2 D	<input type="checkbox"/> Ex ia IIIC T85°C T100°C T120°C Db
- Ambient temperature:

EPL Ga	-40°C ≤ Ta ≤ +60°C
EPL Db	-30°C ≤ Ta ≤ +60°C
EPL Db *	-15°C ≤ Ta ≤ +60°C
- Process temperature:

EPL Ga	-40°C ≤ Tp ≤ +120°C
EPL Db	T120°C -30°C ≤ Tp ≤ +120°C
	T100°C -30°C ≤ Tp ≤ +100°C
	T85°C -30°C ≤ Tp ≤ +80°C
EPL Db *	T120°C -15°C ≤ Tp ≤ +120°C
	T100°C -15°C ≤ Tp ≤ +100°C
	T85°C -15°C ≤ Tp ≤ +80°C

* When FKM O-rings are used. (/HE is specified.)

- Enclosure:
IP66/IP67 in accordance with EN IEC 60079-0
 - Power supply: ≤ 24V, ≤ 24 mA
 - Dielectric strength:
500 V AC, r.m.s., 1 min
- Terminals: to Enclosure
Supply +
Supply -

Note 2. Specific condition of use

When the equipment is mounted in an area where the use of Category 1 G equipment is required, it shall be installed in such a way that, even in the event of rare incidents, an ignition source due to impact and/or friction sparks is excluded.

Precaution shall be taken to minimize the risk from electrostatic discharges or propagating brush discharges on the non-metallic parts (excluding glass parts) or coated parts of the equipment.

The dielectric strength of at least 500 V of the intrinsically safe circuits of the equipment is limited only by the overvoltage protection. From the safety point of view, the intrinsically safe circuit of the equipment shall be assumed to be connected to earth.

Note 3. Installation and erection

Cable entry devices suitable for the thread form and the size of the cable entries must be used, according to the following marking on the equipment.

Screw Size	Marking
ISO M20 × 1.5 female	⚠ M
ANSI 1/2 NPT female	⚠ A or ⚠ N or ⚠ W

F0239.ai

When installing the equipment, the selected Type of Protection should be ticked as follows.

- Ex ia IIC/IIB T4 Ga
- Ex ia IIIC T85°C T100°C T120°C Db

See the installation diagram.

Note 4. Use and setting-up (operation)

If the equipment is mounted in an area where explosive atmospheres may be present, it must be installed in such a way that the risk from electrostatic discharges and propagating brush discharges caused by rapid flow of dust are avoided.

Note 5. Maintenance and repair



WARNING

A modification of the equipment would no longer comply with the construction described in the certificate documentation.

Only personnel authorized by Yokogawa Electric Corporation can repair the equipment.

Model: EJX910A-F Series Date: September 12, 2006

11.0 Drawings
11.1 Installation Diagram

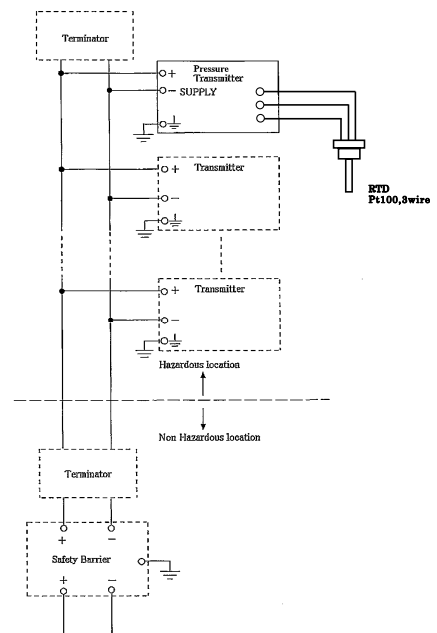

Rev. Doc. No.: IKE032-A12 P.1
Drawing: M.Takeuchi
Approved: H. Sugiyama

IKE032

Yokogawa Electric Corporation

Model: EJX910A-F Series Date: September 12, 2006

- Note
- In the rating 1(*1), the output current of the barrier must be limited by a resistor 'Ra' such that $I_o=U_o/R_a$.
 - In the rating 2(*2), the output of the barrier must be the characteristics of the trapezoid or the rectangle and this transmitter can be connected to Fieldbus equipment which are in according to the FISCO model.
 - The terminators may be built in by a barrier.
 - More than one transmitter may be connected to the power supply line.
 - The terminator and the safety barrier shall be certified.

Electrical data:

Supply circuit	
Maximum Input Voltage U_i : 24V	*1: Rating 1
Maximum Input Current I_i : 250mA	
Maximum Input Power P_i : 1.2W	
Maximum Internal Capacitance C_i : 7.6nF 3.52nF	
Maximum Internal Inductance L_i : 0 μ H Δ	
or	
Maximum Input Voltage U_i : 17.5V	*2: Rating 2
Maximum Input Current I_i : 380mA	
Maximum Input Power P_i : 5.32W	
Maximum Internal Capacitance C_i : 7.6nF 3.52nF	
Maximum Internal Inductance L_i : 0 μ H Δ	
or	
Maximum Input Voltage U_i : 17.5V	
Maximum Input Current I_i : 400mA	
Maximum Input Power P_i : 3.32W	
Maximum Internal Capacitance C_i : 7.6nF 3.52nF	
Maximum Internal Inductance L_i : 0 μ H Δ	

Δ Sensor circuit
Maximum Output Voltage U_o : 7.6V 7.63V
Maximum Output Current I_o : 3.85mA 3.85mA
Maximum Output Power P_o : 0.008W 0.008W
Maximum Internal Capacitance C_o : 4.8nF
Maximum Internal Inductance L_o : 100mH 100mH

Note 2: RTD sensor is prepared by the user.
The sensor signal line must suited a test voltage of 500Vac.

Rev.1: December 14, 2006 M.Takeuchi Doc. No.: IKE032-A12 P.2
Rev.2: October 15, 2011 T.Itou Drawing: M. Takeuchi Approved: H. Sugiyama

IKE032 Yokogawa Electric Corporation

d. ATEX Flameproof Type

Caution for ATEX flameproof type.

Note 1. EJX/EJA-E Series pressure transmitters with optional code /KF22 or /V1F are applicable for use in hazardous locations.

- No. KEMA 07ATEX0109 X
- Applicable Standard:
EN IEC 60079-0
EN 60079-1, EN 60079-31
- Type of Protection and Marking Code:
 Ex II 2 G \square Ex db IIC T6...T4 Gb
II 2 D \square Ex tb IIIC T85°C Db
- Enclosure: IP66 / IP67
- Temperature Class for gas-proof:
T6, T5, and T4
- Ambient Temperature for gas-proof:
-50 to 75°C (T6), -50 to 80°C (T5), and
-50 to 75°C (T4)
- Process Temperature (Tp.) for gas-proof:
-50 to 85°C (T6), -50 to 100°C (T5), and
-50 to 120°C (T4)
- Maximum Surface Temperature for dust-proof:
T85°C (Tamb.: -30* to 75°C, Tp.: -30* to 85°C)
* -15°C when /HE is specified.

Note 2. Electrical Data

- Supply voltage: 42 V dc max.
32 V dc max. (FOUNDATION Fieldbus and PROFIBUS PA type)
9 to 28 V dc, 27 mW (Low Power type)
9 to 30 V dc, 250 mW (RS485 Modbus Communication Type)
- Output signal: 4 to 20 mA
15 mA (FOUNDATION Fieldbus and PROFIBUS PA type)
1 to 5 V (Low Power type)
RS485 Modbus (RS485 Modbus Communication Type)

Note3. For combined approval types Once a device of multiple approval type is installed, it should not be re-installed using any other approval types. Apply a permanent mark in the check box of the selected approval type on the certification label on the transmitter to distinguish it from unused approval types.

Note 4. Installation

- All wiring shall comply with local installation requirement.
- In order to prevent the earthing conductor from loosening, the conductor must be secured to the terminal, tightening the screw with appropriate torque. Care must be taken not to twist the conductor.
- Cable glands, adapters and/or blanking elements with a suitable IP rating shall be of Ex d IIC/Ex tb IIIC certified by ATEX and shall be installed so as to maintain the specific degree of protection (IP Code) of the equipment.
- Wiring connection for output signal code Q (Low Power type) shall follow the diagram below.

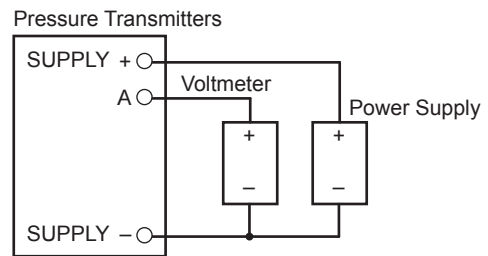

Three-Wire Connection

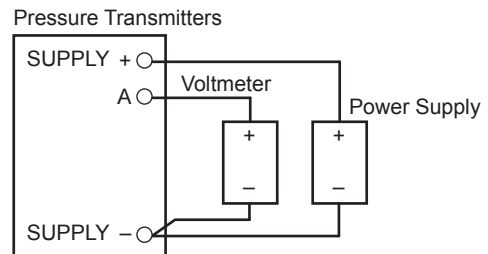

Four-Wire Connection

F0220.ai

- Installation and erection:
Cable entry devices suitable for the thread form and the size of the cable entries must be used, according to the following marking on the equipment.

Screw Size	Marking
ISO M20 × 1.5 female	△ M
ANSI 1/2 NPT female	△ A or △ N or △ W

F0239.ai

When installing the equipment, the selected Type of Protection should be ticked as follows.

- Ex ic IIC T4 Gc
- Ex ia IIC T4 Ga

- Use and setting-up (operation):
If the pressure transmitter is mounted in an area where explosive atmospheres may be present, it must be installed in such a way that the risk from electrostatic discharges is avoided.
- Maintenance and repair



WARNING

A modification of the equipment would no longer comply with the construction described in the certificate documentation.

Only personnel authorized by Yokogawa Electric Corporation can repair the equipment.

Yokogawa Electric Corporation		Model		EJX Series	
Title	Control drawing	Prepared by	M. Inatomi	Approved by	D. Harada
No.	IKE046-A70	Page	1	Revision	2
Revised pages		Date	2020-09-02		

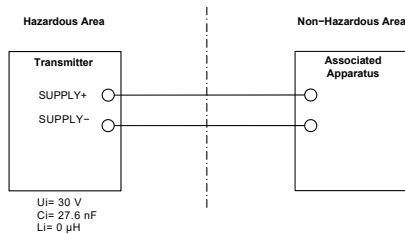

f. ATEX Intrinsically Safe Ex ic for Fieldbus Type (Except for EJX9□0A)

Caution for ATEX Intrinsically safe Ex ic.

Note 1. The transmitters with option code /KN26 for potentially explosive atmospheres

Applicable Standard:
EN IEC 60079-0, EN 60079-11

Note 2. Rating

Ex Marking:
⊕ II 3 G Ex ic IIC T4 Gc

Temperature specifications:

Ambient temperature range	Process temperature range	Type of O-ring
-30 to 60°C	-30 to 120°C	NBR
-15 to 60°C	-15 to 120°C	Fluoro-rubber (FKM)

IP Code: IP66

Overvoltage Category: I

Electrical Parameters: See control drawing
IKE047-A70 (Note 7.)

Note 3. Installation:

- See control drawing IKE047-A70. (Note 7.)
- The type of threads is indicated at the cable entry, using the following marking.

Screw Size	Marking
ISO M20 × 1.5 female	△ M
ANSI 1/2 NPT female	△ A or △ N or △ W

F0239.ai

Note 4. Operation

If the pressure transmitter is mounted in an area where explosive atmospheres may be present, it must be installed in such a way that the risk from electrostatic discharges is avoided.

Note 5. Specific conditions of use

See control drawing IKE047-A70 (Note 7.)

Note 6. Maintenance and Repair

Only personnel authorized by Yokogawa Electric Corporation can repair the equipment.

Note 7. Control drawing

Model: EJX Series Date: February 28, 2013

14 Control Drawing

Following instructions shall be included in the user's manual, together with the following items:

- a list of the standards in 1, including the issue year;
- specifications in 2;
- marking information in 13.

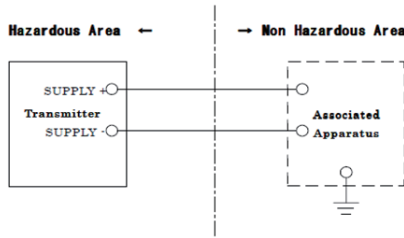

Electrical data are as follows:

U_i = 32 V
C_i = 3.52 nF
L_i = 0 μH

Specific Conditions of Use:

Precautions shall be taken to minimize the risk from electrostatic discharge of painted parts.

The dielectric strength of at least 500 V a.c. r.m.s between the intrinsically safe circuits and the enclosure of the Pressure Transmitter Model EJX Series, Model EJA***E Series and Model EJA***J Series are limited only by the overvoltage protection.

WARNING:

POTENTIAL ELECTROSTATIC CHARGING HAZARD - SEE USER'S MANUAL.

Note:

Cable glands, adapters and/or blanking elements shall be of type "n", type "e" or type "d" and shall be installed so as to maintain the specified degree of protection (IP Code) of the equipment.

Rev. Doc. No.: IKE047-A70
Drawing: T.Ito
Approved: A.Matsunaga

(2) Electrical Connection

A mark indicating the electrical connection type is stamped near the electrical connection port.

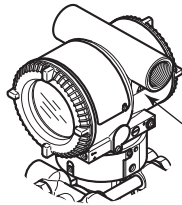

Location of the mark

F0214.ai

(3) Name Plate

● Name plate

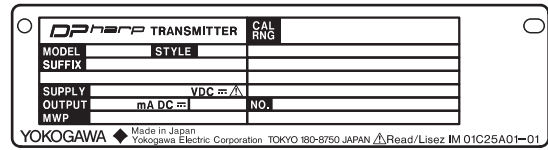

● Tag plate for flameproof type

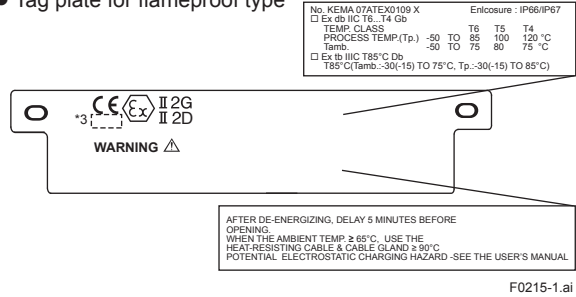

[Except for EJX9□0A]

● Tag plate for intrinsically safe Ex ia for HART/BRAIN

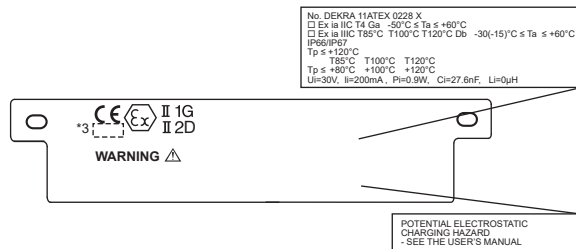

● Tag plate for ATEX intrinsically safe or ATEX flameproof for HART/BRAIN

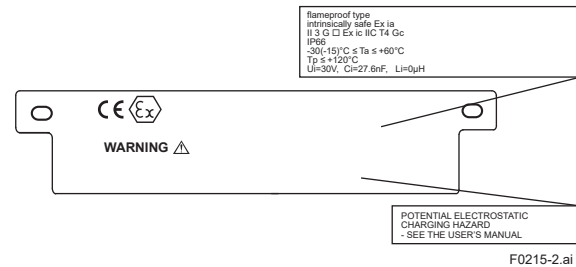

● Tag plate for intrinsically safe Ex ia for Fieldbus

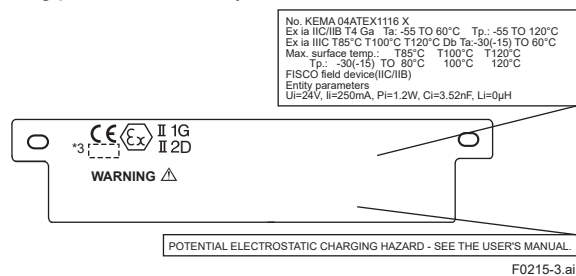

- Tag plate for intrinsically safe Ex ic for Fieldbus

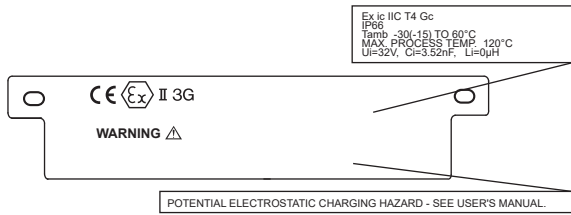

[EJX9□0A]

- Tag plate for intrinsically safe Ex ia for Fieldbus

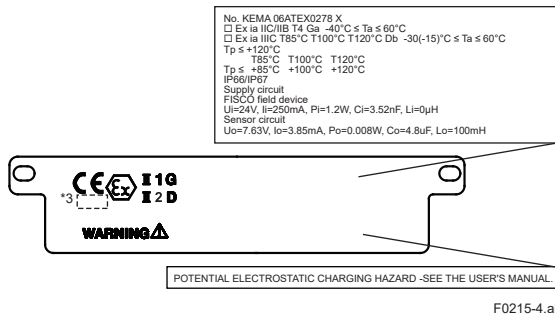

F0215-4.ai

- MODEL: Specified model code.
- STYLE: Style code.
- SUFFIX: Specified suffix code.
- SUPPLY: Supply voltage.
- OUTPUT: Output signal.
- MWP: Maximum working pressure.
- CAL RNG: Specified calibration range.
- NO.: Serial number and year of production^{*1}.
- TOKYO 180-8750 JAPAN: The manufacturer name and the address^{*2}.

*1: The first number in the second block of "NO." column is the last one number of the production year.



NO. 91K819857 132 7

The year 2011

*2: "180-8750" is a zip code which represents the following address.

2-9-32 Nakacho, Musashino-shi, Tokyo Japan

*3: The identification number of Notified Body.

2.4.4 IECEx Certification

Model EJX Series pressure transmitters with optional code /SU21 or /SU22 can be selected the type of protection (IECEx Intrinsically Safe Ex ia, Ex ic or flameproof) for use in hazardous locations.

EJX Series pressure transmitters with optional code /SS26 can be selected the type of protection (IECEx intrinsically safe Ex ia or Ex ic) for use in hazardous locations.

Note 1. For the installation of this transmitter, once a particular type of protection is selected, any other type of protection cannot be used. The installation must be in accordance with the description about the type of protection in this instruction manual.

Note 2. For combined approval types, once a device of multiple approval type is installed, it should not be re-installed using any other approval types. Apply a permanent mark in the check box of the selected approval type on the certification label on the transmitter to distinguish it from unused approval types.

a. IECEx Intrinsically Safe Ex ia for HART/ BRAIN Protocol Type (Except for EJX9□0A)

Caution for IECEx Intrinsically safe Ex ia.

Note 1. EJX/EJA-E series pressure transmitters with optional code /SU21 or /SU22 are applicable for use in hazardous locations

- Applicable standards: IEC 60079-0, IEC 60079-11
 - Certificate number: IECEx DEK 11.0081X
 - Specific Ex marking: Ex ia IIC T4 Ga
 - Ambient temperature: $-50^{\circ}\text{C} \leq T_a \leq +60^{\circ}\text{C}$
 - Process temperature: $-50^{\circ}\text{C} \leq T_p \leq +120^{\circ}\text{C}$
 - Enclosure: IP66/IP67 in accordance with IEC 60079-0
 - Power supply: $\leq 30\text{ V}, \leq 21.6\text{ mA}$
 - Dielectric strength: 500 V AC, r.m.s., 1 min
- Terminals: to Enclosure
Supply +
Supply -

Note 2. Specific condition of use

When the equipment is mounted in an area where the use of EPL Ga equipment is required, it shall be installed in such a way that, even in the event of rare incidents, an ignition source due to impact and/or friction sparks is excluded.

Precaution shall be taken to minimize the risk from electrostatic discharges or propagating brush discharges on the non-metallic parts (excluding glass parts) or coated parts of the equipment.

The dielectric strength of at least 500 V of the intrinsically safe circuits of the equipment is limited only by the overvoltage protection. From the safety point of view, the intrinsically safe circuit of the equipment shall be assumed to be connected to earth.

Note 3. Installation and erection

Cable entry devices suitable for the thread form and the size of the cable entries must be used, according to the following marking on the equipment.

Screw Size	Marking
ISO M20 × 1.5 female	⚠ M
ANSI 1/2 NPT female	⚠ A or ⚠ N or ⚠ W

F0239.ai

When installing the equipment, the selected Type of Protection should be ticked as follows.

- Ex ia IIC T4 Ga
- Ex ic IIC T4 Gc

See the control drawing.

Note 4. Use and setting-up (operation)

If the equipment is mounted in an area where explosive atmospheres may be present, it must be installed in such a way that the risk from electrostatic discharges and propagating brush discharges caused by rapid flow of dust are avoided.

Note 5. Maintenance and repair



WARNING

A modification of the equipment would no longer comply with the construction described in the certificate documentation.

Only personnel authorized by Yokogawa Electric Corporation can repair the equipment.

Yokogawa Electric Corporation		Model		EJX Series	
Title	Control drawing (General)				
No.	IKE045-A91	Page	1	Revision	0
Date	2020-08-07				

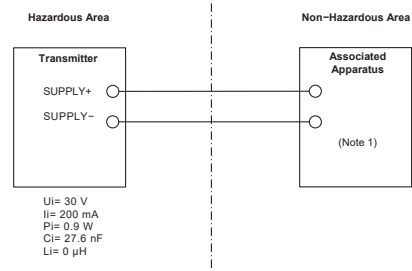

Notes:
1. Associated Apparatus must be a linear power source whose output current is resistively limited.

b. IECEx Intrinsically Safe Ex ic for HART/ BRAIN Protocol Type (Except for EJX9□0A)

Caution for IECEx Intrinsically safe Ex ic.

Note 1. EJX/EJA-E series pressure transmitters with optional code /SU21 or /SU22 are applicable for use in hazardous locations

- Applicable Standard: IEC 60079-0, IEC 60079-11
- Certificate number: IECEx DEK 13.0061X
- Specific Ex marking: Ex ic IIC T4 Gc
- Ambient Temperature: $-30^{\circ}\text{C} \leq T_a \leq +60^{\circ}\text{C}$
 $-15^{\circ}\text{C} \leq T_a \leq +60^{\circ}\text{C}^*$
- Process Temperature: $-30^{\circ}\text{C} \leq T_p \leq +120^{\circ}\text{C}$
 $-15^{\circ}\text{C} \leq T_p \leq +120^{\circ}\text{C}^*$

* When FKM O-rings are used. (/HE is specified.)

- Enclosure: IP66
 - Pollution degree: 2
 - Overvoltage category: I
 - Power supply: $\leq 30\text{ V}, \leq 21.6\text{ mA}$
 - Dielectric strength:
500 V AC, r.m.s., 1 min
- Terminals: to Enclosure
Supply +
Supply -

Note 2. Specific condition of use

- Precaution shall be taken to minimize the risk from electrostatic discharges on the non-metallic parts (excluding glass parts) or coated parts of the equipment.
- The dielectric strength of at least 500 V of the intrinsically safe circuits of the equipment is limited only by the overvoltage protection. From the safety point of view, the intrinsically safe circuit of the equipment shall be assumed to be connected to earth.

Note 3. Installation and erection

Cable entry devices suitable for the thread form and the size of the cable entries must be used, according to the following marking on the equipment.

Screw Size	Marking
ISO M20 × 1.5 female	⚠ M
ANSI 1/2 NPT female	⚠ A or ⚠ N or ⚠ W

F0239.ai

When installing the equipment, the selected Type of Protection should be ticked as follows.

- Ex ic IIC T4 Gc
- Ex ia IIC T4 Ga

Note 4. Use and setting-up (operation)

If the pressure transmitter is mounted in an area where explosive atmospheres may be present, it must be installed in such a way that the risk from electrostatic discharges is avoided.

Note 5. Maintenance and repair



WARNING

A modification of the equipment would no longer comply with the construction described in the certificate documentation.

Only personnel authorized by Yokogawa Electric Corporation can repair the equipment.

Yokogawa Electric Corporation		Model	EJX Series	
Title	Control drawing			
No.	IIE019-A70	Page	-	Revision 7 Date 2023-08-21

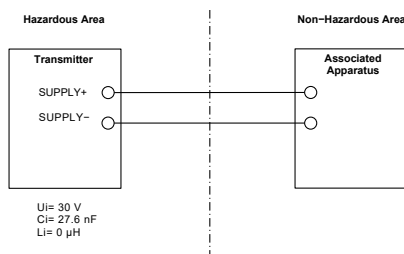

c. IECEx Intrinsically Safe Ex ia for Fieldbus Type (Except for EJX□0A)

Caution for IECEx Intrinsically safe Ex ia.

Note 1. EJX/EJA-E Series pressure transmitters with optional code /SS26 are applicable for use in hazardous locations.

Certification Information:



WARNING

A modification of the equipment would no longer comply with the construction described in the certificate documentation.

Certificate Number:
IECEX DEK 12.0016X



NOTE

The symbol "X" placed after the certificate number indicates that the equipment is subject to specific conditions of use.

- Applicable Standard
IEC 60079-0
IEC 60079-11

Note 2. Rating

Ex Marking:

Ex ia IIC/IIB T4 Ga

Temperature specifications:

Ambient Temperature range and Process

Temperature range for Gas:

Ambient temperature range	Process temperature range
-55 to 60°C	-55 to 120°C

Electrical Parameters:

Intrinsically safe ratings are as follows:

[Entity]

- Ui = 24 V
- Ii = 250 mA
- Pi = 1.2 W
- Ci = 3.52 nF
- Li = 0 μH

[FISCO IIC]

- Ui = 17.5 V
- Ii = 380 mA
- Pi = 5.32 W
- Ci = 3.52 nF
- Li = 0 μH

[FISCO IIB]

- Ui = 17.5 V
- Ii = 460 mA
- Pi = 5.32 W
- Ci = 3.52 nF
- Li = 0 μH

Note 3. Installation

- Refer to the control drawing IKE022-A12 P.1 and P.2. (Note 7.)
- The type of threads is indicated at the cable entry, using the following marking.

Screw Size	Marking
ISO M20 × 1.5 female	△ M
ANSI 1/2 NPT female	△ A or △ N or △ W

F0239.ai

- The selected type of the Ex marking on the name plate should be indicated. For this purpose, the tick boxes can be used as follows.
 - Ex ia IIC/IIB T4 Ga
 - Ex ic IIC T4 Gc

Note 4. Operation

- If the pressure transmitter is mounted in an area where explosive atmospheres may be present, it must be installed in such a way that the risk from electrostatic discharges and propagating brush discharges caused by rapid flow of dust are avoided.

Note 5. Specific conditions of use

- When the pressure transmitter is made of aluminum alloy, if it is mounted in an area where the use of EPL Ga equipment is required, it shall be installed such that, even in the event of rare incidents, an ignition source due to impact and friction sparks is excluded.
- Precautions shall be taken to minimize the risk from electrostatic discharge of painted parts.
- The dielectric strength of at least 500 V of the intrinsically safe circuits of the pressure transmitter is limited only by the overvoltage protection.

Note 6. Maintenance and Repair

- Only personnel authorized by Yokogawa Electric Corporation can repair the equipment.

Note 7. Control drawing

Model: EJX Series Date: March 31, 2004

11.0 Drawings
11.1 Installation Diagram

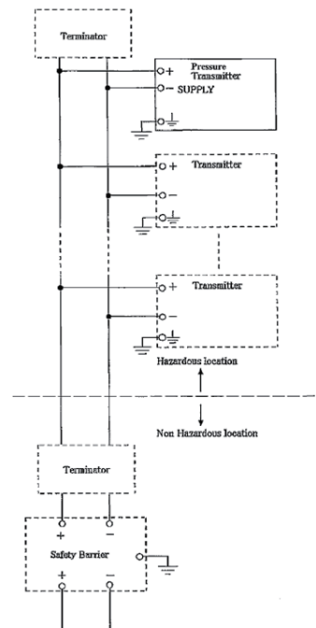

Rev.	Doc. No.:	IKE022-A12 P.1
	Drawing:	Y. Takamuku
	Approved:	K. Masuki

Model: EJX Series Date: March 31, 2004

Note

- In the rating 1(*1), the output current of the barrier must be limited by a resistor 'Ra' such that $I_o = U_o/R_a$.
- In the rating 2(*2), the output of the barrier must be the characteristics of the trapezoid or the rectangle and this transmitter can be connected to Fieldbus equipment which are in according to the FISCO model.
- The terminators may be built in by a barrier.
- More than one transmitter may be connected to the power supply line.
- The terminator and the safety barrier shall be certified.

Electrical data:

Maximum Input Voltage U_i : 24V	} *1: Rating 1
Maximum Input Current I_i : 250mA	
Maximum Input Power P_i : 1.2W	
Maximum Internal Capacitance C_i : 4.76nF 3.52nF △	
Maximum Internal Inductance L_i : 0 μ H	
or	
Maximum Input Voltage U_i : 17.5V	} *2: Rating 2
Maximum Input Current I_i : 380mA △	
Maximum Input Power P_i : 2.56W 5.32W △	
Maximum Internal Capacitance C_i : 4.76nF 3.52nF △	
Maximum Internal Inductance L_i : 0 μ H	
or	
Maximum Input Voltage U_i : 17.5V	
Maximum Input Current I_i : 460mA	
Maximum Input Power P_i : 5.32W	
Maximum Internal Capacitance C_i : 4.76nF 3.52nF △	
Maximum Internal Inductance L_i : 0 μ H	

Rev.△ July 16, 2004	Y. Takamuku	Doc. No.:	IKE022-A12 P.2
Rev.2: October 15, 2011	A. Okada	Drawing:	Y. Takamuku
		Approved:	K. Masuki

d. IECEx Intrinsicly Safe Ex ic for Fieldbus Type (Except for EJX□0A)

Caution for IECEx Intrinsicly safe Ex ic.

Note 1. EJX/EJA-E Series pressure transmitters with optional code /SS26 are applicable for use in hazardous locations.

Certification Information:



WARNING

A modification of the equipment would no longer comply with the construction described in the certificate documentation.

Certificate Number:
IECEX DEK 13.0064X



NOTE

The symbol "X" placed after the certificate number indicates that the equipment is subject to specific conditions of use.

Applicable Standard:
IEC 60079-0, IEC 60079-11

Note 2. Ratings

Ex Marking: Ex ic IIC T4 Gc
Temperature specifications:

Ambient temperature range	Process temperature range	Type of O-ring
-30 to 60°C	-30 to 120°C	NBR
-15 to 60°C	-15 to 120°C	Fluoro-rubber (FKM)

IP Code: IP66
Overvoltage Category: I
Electrical Parameters: See control drawing IIE020-A70 (Note 7.)

Note 3. Installation

- See control drawing IIE020-A70. (Note 7.)
- The type of threads is indicated at the cable entry, using the following marking.

Screw Size	Marking
ISO M20 × 1.5 female	△ M
ANSI 1/2 NPT female	△ A or △ N or △ W

F0239.ai

- The selected type of the Ex marking on the name plate should be indicated. For this purpose, the tick boxes can be used as follows.
 - Ex ia IIC/IIB T4 Ga
 - Ex ic IIC T4 Gc

Note 4. Operation

- If the pressure transmitter is mounted in an area where explosive atmospheres may be present, it must be installed in such a way that the risk from electrostatic discharges and propagating brush discharges caused by rapid flow of dust are avoided.

Note 5. Specific conditions of use

- See control drawing IIE020-A70 (Note 7.)

Note 6. Maintenance and Repair

- Only personnel authorized by Yokogawa Electric Corporation can repair the equipment.

Note 7. Control drawing

Model: EJX Series Date: April 01, 2013

13 Control Drawing

Following instructions shall be included in the user's manual, together with the following items:

- a list of the standards in Section 1 of IIE020-A03, including the issue year;
- specifications in Section 2 of IIE020-A03;
- marking information in IIE020-A60.

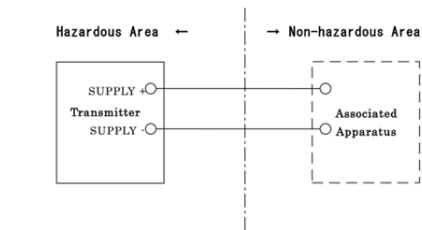

Electrical data: $U_i = 32\text{ V}$
 $C_i = 3.52\text{ nF}$
 $L_i = 0\text{ }\mu\text{H}$

Specific Conditions of Use:

- Precautions shall be taken to minimize the risk from electrostatic discharge of painted parts.
- The dielectric strength of at least 500 V a.c. r.m.s. between the intrinsically safe circuits and the enclosure of the pressure transmitter is limited only by the overvoltage protection.

WARNING:
- POTENTIAL ELECTROSTATIC CHARGING HAZARD - SEE THE USER'S MANUAL

- Notes:
- The pressure transmitter is allowed to be installed in "nL" systems, on condition that the output parameters of the "nL" source (associated energy-limited apparatus) are suitable to the above-mentioned input parameters of the pressure transmitter and the cable parameters.
 - Cable glands, adapters and/or blanking elements shall be of Ex "n", Ex "e" or Ex "d" and shall be installed so as to maintain the specified degree of protection (IP Code) of the equipment.
 - In case of multiple types of protection, the selected Ex marking on the marking plate shall be checked at the time of installation.

Rev.1: September 02, 2019 Doc. No.: IIE020-A70
Drawing: T.Itou
Approved: A.Matsunaga

Yokogawa Electric Corporation

e. IECEx Flameproof Type

Caution for IECEx flameproof type.

Note 1. EJX/EJA-E Series pressure transmitters with optional code /SF2 or /SU21 are applicable for use in hazardous locations:

- No. IECEx CSA 07.0008
- Applicable Standard: IEC60079-0:2011, IEC60079-1:2007-4
- Flameproof for Zone 1, Ex d IIC T6...T4 Gb
- Enclosure: IP66/IP67
- Maximum Process Temperature: 120°C (T4), 100°C (T5), 85°C (T6)
- Ambient Temperature: -50 to 75°C (T4), -50 to 80°C (T5), -50 to 75°C (T6)
- Supply Voltage: 42 V dc max. 32 V dc max. (FOUNDATION Fieldbus and PROFIBUS PA type) 9 to 28 V dc, 27 mW (Low Power type) 9 to 30 V dc, 250 mW (RS485 Modbus Communication Type)
- Output Signal: 4 to 20 mA dc 15 mA (FOUNDATION Fieldbus and PROFIBUS PA type) 1 to 5 V (Low Power type) RS485 Modbus (RS485 Modbus Communication Type)

Note 2. Wiring

- In hazardous locations, the cable entry devices shall be of a certified flameproof type, suitable for the conditions of use and correctly installed.
- Unused apertures shall be closed with suitable flameproof certified blanking elements.
- Wiring connection for output signal code Q (Low Power type) shall follow the diagram below.

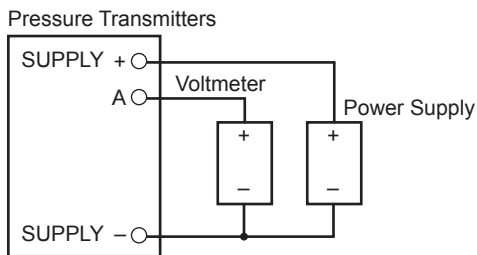

Three-Wire Connection

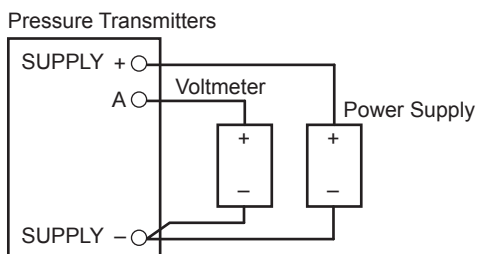

Four-Wire Connection

F0221.ai

Note 3. Operation

- WARNING: AFTER DE-ENERGIZING, DELAY 5 MINUTES BEFORE OPENING.
- WARNING: WHEN THE AMBIENT TEMP. ≥ 65°C, USE HEAT-RESISTING CABLE AND CABLE GLAND ≥ 90°C.
- Take care not to generate mechanical sparking when accessing to the instrument and peripheral devices in a hazardous location.
- Electrostatic charge may cause an explosion hazard. Avoid any actions that cause the generation of electrostatic charge, such as rubbing with a dry cloth on coating face of the product.

Note 4. Maintenance and Repair

- The instrument modification or parts replacement by other than authorized representative of Yokogawa Electric Corporation is prohibited and will void IECEx Certification.
- Electrical Connection A mark indicating the electrical connection type is stamped near the electrical connection port. These marks are as followed.

Screw Size	Marking
ISO M20 × 1.5 female	△ M
ANSI 1/2 NPT female	△ N or △ W

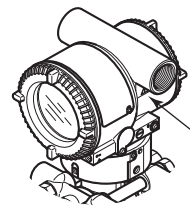

Location of the mark

F0222.ai

f. IECEx Flameproof Type

Caution for IECEx flameproof type.

Note 1. EJX/EJA-E Series pressure transmitters with optional code /SF22 or /SU22* are applicable for use in hazardous locations:

* /SU22: Except for Fieldbus Communication Type, PROFIBUS PA Type, EJX910A, EJX930A

- No. IECEx DEK 14.0046X
- Applicable Standard: IEC60079-0, IEC60079-1, IEC 60079-31
- Type of Protection and Marking Code: □ Ex db IIC T6...T4 Gb □ Ex tb IIIC T85°C Db
- Enclosure: IP66/IP67
- Temperature Class for gas-proof: T6, T5, and T4
- Ambient Temperature for gas-proof: -50 to 75°C (T6), -50 to 80°C (T5), and -50 to 75°C (T4)

- Process Temperature (Tp.) for gas-proof: -50 to 85°C (T6), -50 to 100°C (T5), and -50 to 120°C (T4)
- Maximum Surface Temperature for dust-proof: T85°C (Tamb.: -30* to 75°C, Tp.: -30* to 85°C) * -15°C when /HE is specified.

Note 2. Electrical Data

- Supply voltage: 42 V dc max. 32 V dc max. (FOUNDATION Fieldbus and PROFIBUS PA type) 9 to 30 V dc, 250 mW (RS485 Modbus Communication Type) 9 to 28 V dc, 27 mW (Low Power type)
- Output signal: 4 to 20 mA, 15 mA (FOUNDATION Fieldbus and PROFIBUS PA type) RS485 Modbus (RS485 Modbus Communication Type), 1 to 5 Vdc (Low Power type)

Note 3. For combined approval types Once a device of multiple approval type is installed, it should not be re-installed using any other approval types. Apply a permanent mark in the check box of the selected approval type on the certification label on the transmitter to distinguish it from unused approval types.

Note 4. Installation

- All wiring shall comply with local installation requirement.
- In order to prevent the earthing conductor from loosening, the conductor must be secured to the terminal, tightening the screw with appropriate torque. Care must be taken not to twist the conductor.
- Cable glands, adapters and/or blanking elements with a suitable IP rating shall be of Ex d IIC/Ex tb IIIC certified by IECEx and shall be installed so as to maintain the specific degree of protection (IP Code) of the equipment.
- Wiring connection for output signal code Q (Low Power type) shall follow the diagram below.

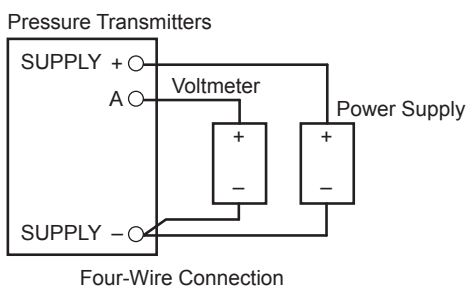
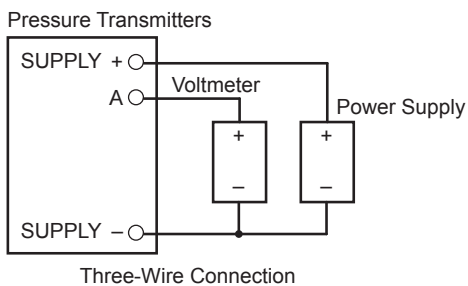

F0221.ai

- Electrical Connection
A mark indicating the electrical connection type is stamped near the electrical connection port. These marks are as followed.

Screw Size	Marking
ISO M20 × 1.5 female	△ M
ANSI 1/2 NPT female	△ N or △ W

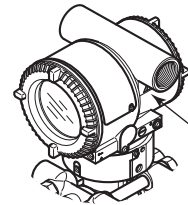

Location of the mark

F0222.ai

Note 5. Operation

- Keep the "WARNING" label a the transmitter.
- WARNING:
- AFTER DE-ENERGIZING, DELAY 5 MINUTES BEFORE OPENING. WHEN THE AMBIENT TEMP. ≥ 65°C, USE HEAT-RESISTING CABLE AND CABLE GLAND ≥ 90°C.
- Take care not to generate mechanical sparking when accessing to the instrument and peripheral devices in a hazardous location.

Note 6. Maintenance and Repair

- WARNING:
- When maintenance and repair are performed, confirm the following conditions and the then perform works Confirm the power supply is cut off and the voltage of power supply terminal is not supplied.
- Only personnel authorized by Yokogawa Electric Corporation can repair the equipment in accordance with the relevant standards: IEC 60079-19 (Equipment repair, overhaul and reclamation) and IEC 60079-17 (Electrical installation inspection and maintenance); otherwise the certification will be voided.

Note 7. Specific Conditions of Use

- WARNING
- Electrostatic charge may cause an explosion hazard. Avoid any actions that cause the generation of electrostatic charge, such as rubbing with a dry cloth on coating face of the product.
- The flame paths differ from the standard values in IEC 60079-1. Repair of the equipment is only allowed when done by the manufacturer or an authorized representative.
- The fasteners used to fasten the transmitter enclosure onto the sensor capsule is special fastener, and the property class of it is A2-50 (A4-50) or more.

- For transmitters with a membrane made of titanium, ignition hazard due to impact and friction on the membranes shall be avoided.
- Maximum Surface Temperature for dust-proof: T85°C (Tamb.: -30* to 75°C, Tp.: -30* to 85°C)
* -15°C when /HE is specified.

2.5 EMC Conformity Standards

EN 61326-1 Class A, Table 2
EN 61326-2-3
EN 61326-2-5 (for Fieldbus)



CAUTION

To meet EMC regulations, Yokogawa recommends that customers run signal wiring through metal conduits or use shielded twisted-pair cabling when installing EJX/EJA-E Series transmitters in a plant. This equipment is a Class A product, and it is designed for use in the industrial environment. Please use this instrument in the industrial environment only.

2.6 Pressure Equipment Directive (PED)

(1) General

- EJX/EJA-E Series pressure transmitters are categorized as piping under the pressure accessories section of directive 2014/68/EU, which corresponds to Article 4, Paragraph 3 of PED, denoted as Sound Engineering Practice (SEP).
- EJX110A-□MS, EJX110A-□HS, EJX110A-□VS, EJA110E with /HG, EJ□130□, EJ□440□, EJ□510□-□D, EJ□530□-□D, EJX610A-□D, and EJX630A-□D can be used above 200 bar and therefore considered as a part of a pressure retaining vessel where category III, Module H applies. These models with option code /PE3 conform to that category.

(2) Technical Data

- Models without /PE3
Article 4, Paragraph 3 of PED, denoted as Sound Engineering Practice (SEP).
- Models with /PE3
Module: H
Type of Equipment: Pressure Accessory-Vessel
Type of fluid: Liquid and Gas
Group of fluid: 1 and 2

Model	Capsule code	PS*1 (bar)	V (L)	PS.V (bar.L)	TS*2 (°C)	Category*3
EJA110E	M, H, V	160	0.01	1.6	-40 to 120	Article 4, Paragraph 3 (SEP)
EJ□110□	F, L					
EJX110A	M, H, V	250	0.01	2.5		
EJA110E with code /HG						
EJ□110□ with code /PE3	M, H, V	250	0.01	2.5	-29 to 120	III
EJ□130□	M, H, V	500	0.01	5.0	-40 to 120	Article 4, Paragraph 3 (SEP)
EJ□130□ with code /PE3	M, H, V	500	0.01	5.0		III
EJ□310□	L	160	0.01	1.6	-40 to 100	Article 4, Paragraph 3 (SEP)
	M, A, B				-40 to 120	
EJ□430□	H, A, B	160	0.01	1.6	-40 to 120	Article 4, Paragraph 3 (SEP)
EJ□440□	C, D	500	0.01	5.0	-40 to 120	Article 4, Paragraph 3 (SEP)
EJ□440□ with code /PE3	C, D	500	0.01	5.0		III
EJ□510□ EJX610A	A, B, C	100	0.1	10	-40 to 120	Article 4, Paragraph 3 (SEP)
	D	700	0.1	70		
EJ□510□, EJX610A with code /PE3	D	700	0.1	70		III
EJ□530□, EJX630A	A, B, C	100	0.1	10	-40 to 120	Article 4, Paragraph 3 (SEP)
	D	700	0.1	70		
EJ□530□, EJX630A with code /PE3	D	700	0.1	70		III
EJX910A	L	160	0.01	1.6	-40 to 120	Article 4, Paragraph 3 (SEP)
	M, H	250	0.01	2.5		
EJX910A with code /PE3	M, H	250	0.01	2.5	-29 to 120	III
EJX930A	M, H	500	0.01	5.0	-40 to 120	Article 4, Paragraph 3 (SEP)
EJX930A with code /PE3	M, H	500	0.01	5.0		III

*1: PS is maximum pressure for vessel itself based on Pressure Equipment Directive 2014/68/EU. Refer to General Specification for maximum working pressure of a transmitter.

*2: TS is process temperature limits for vessel itself based on Pressure Equipment Directive 2014/68/EU. Refer to General Specification for temperature limits of a transmitter.

*3: Referred to Table 1 covered by ANNEX II of EC Directive on Pressure Equipment Directive 2014/68/EU.

(3) Operation



CAUTION

- The temperature and pressure of fluid should be maintained at levels that are consistent with normal operating conditions.
- The ambient temperature should be maintained at a level that is consistent with normal operating conditions.
- Please take care to prevent water hammer and the like from inducing excessive pressures in pipes and valves. If phenomena are likely, install a safety valve or take some other appropriate measure to prevent pressure from exceeding PS.
- Take appropriate measures at the device or system level to protect transmitters if they are to be operated near an external heat source.

2.7 EU RoHS Directive

Applicable standard: EN IEC 63000

Applicable production sites are shown below.

The condition of the RoHS compliant production sites are as follows:

Japan, Germany, Saudi Arabia, UAE, India, USA

The production sites can be confirmed by the serial number shown in the frame of "NO." in the name plate of the product.

Serial numbers (9 letters): **AA**nnnnnnnn

AA: Identification code of production site

Japan: Use "91" or "90"

USA: Use "U1"

Germany: Use "D1"

Saudi Arabia: Use "Y3"

UAE: Use "Y4"

India: Use "Y1"

2.8 Safety Requirement Standards

Applicable standard: EN 61010-1, EN 61010-2-30, C22.2 No.61010-1, C22.2 No.61010-2-030

(1) Pollution Degree 2

"Pollution degree" describes the degree to which a solid, liquid, or gas which deteriorates dielectric strength or surface resistivity is adhering. " 2 " applies to normal indoor atmosphere. Normally, only non-conductive pollution occurs. Occasionally, however, temporary conductivity caused by condensation must be expected.

(2) Installation Category I

"Overvoltage category(Installation category)" describes a number which defines a transient overvoltage condition. It implies the regulation for impulse withstand voltage. " I " applies to electrical equipment which is supplied from the circuit when appropriate transient overvoltage control means (interfaces) are provided.

(3) Indoor/Outdoor use

It can be used indoors and outdoors.

(4) Altitude of installation site

Max. 5,000 m above sea level

3. Installation



IMPORTANT

- When welding piping during construction, take care not to allow welding currents to flow through the transmitter.
- Do not step on this instrument after installation.
- For EJ□430□, EJ□440□ and EJ□438□, the atmospheric opening is located on the low pressure side cover flange. For EJ□530□ and EJX630A whose capsule code is A, B, or C, the pipe of the atmospheric opening is located on the pressure detecting section. These openings must not face upward.

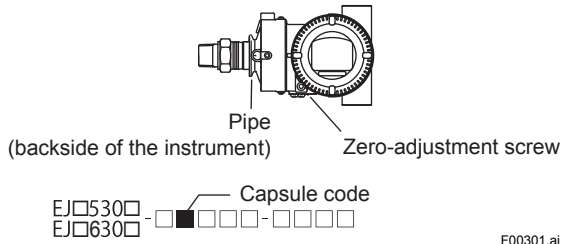

Figure 3.1 EJ□530□ and EJX630A Horizontal Mounting Position

- When installing diaphragm seals, process connectors or manifolds, make sure that no foreign matter has adhered to the seal surface of the gasket (or O-ring) before assembling. If foreign matter adheres, it may lead to leaks.

3.1 Mounting

- The transmitter can be mounted on a nominal 2-inch pipe using the mounting bracket supplied, as shown in Figure 3.2 and 3.3. Tighten the (four) bolts that hold the transmitter with a torque of approximately 39 N·m {4 kgf·m}.

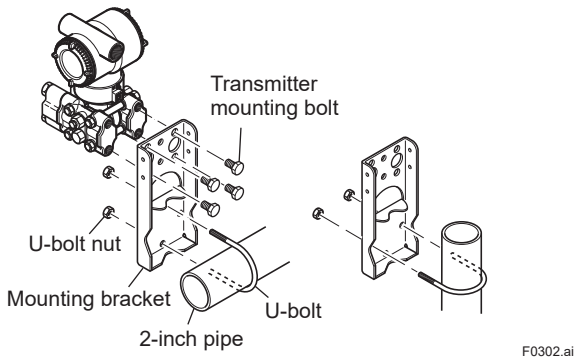
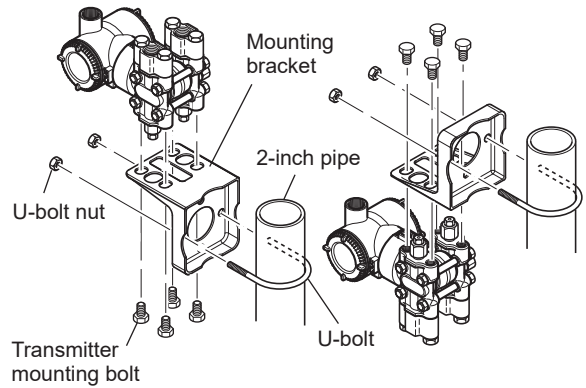

Figure 3.2 Transmitter Mounting (Horizontal Impulse Piping Type)

Vertical pipe mounting (Process connector upside) Vertical pipe mounting (Process connector downside)



- In the case of position adjustable bracket

Vertical pipe mounting (Process connector upside) Vertical pipe mounting (Process connector downside)

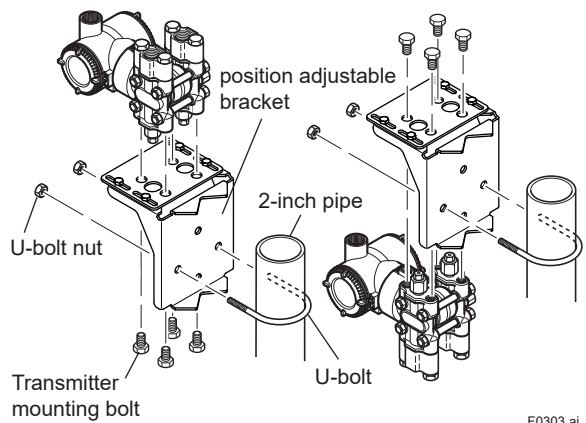

Figure 3.3 Transmitter Mounting (Vertical Impulse Piping Type)

Vertical pipe mounting

Horizontal pipe mounting

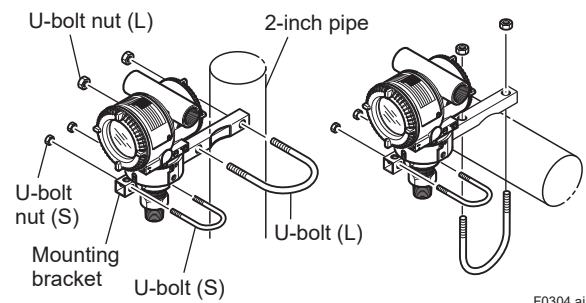

Figure 3.4 EJ□510□ and EJ□530□ Mounting

3.1.1 How to install the position adjustable bracket

The procedures for mounting the transmitter with the position adjustable bracket (L type) are described below. (see Figure 3.5)

- (1) Securely fix the transmitter and the position adjustable plate using the transmitter mounting bolts. Tighten the transmitter mounting four bolts with a torque of approximately 39 N·m {4 kgf·m}.
- (2) Attach the bracket to the 2-inch pipe while adjusting the height to the process piping.
- (3) Loosen the position adjustment screw and slide the position adjustable plate on the bracket to align the position of the 2-inch pipe and the process piping.* 1
- (4) Tighten each of the position adjustment four bolts to firmly fix the position adjustable plate and the bracket. After fixing, check that it does not move.

Process connection upside

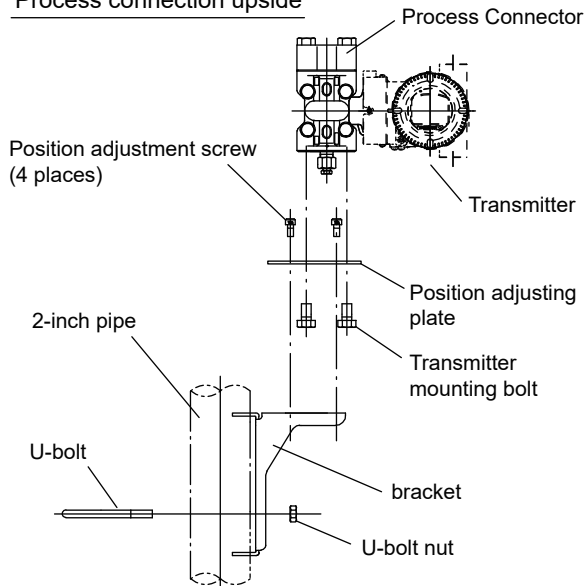

Process connection downside

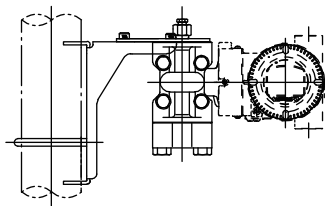

Mount the bracket in the direction as described in the figure.

F0315.ai

Figure 3.5 Mounting with the position adjustable bracket

*1: The position adjustment plate can be adjusted in the range of 75 to 132 mm depending on the mounting direction to the bracket. The adjustment range varies depending on the model and specifications. (see Figures 3.6 to 3.7)

*2: When the EJX930A specified as “process connector downside”, the position adjustment plate can be used only in the inverted state shown in Figure 3.7.

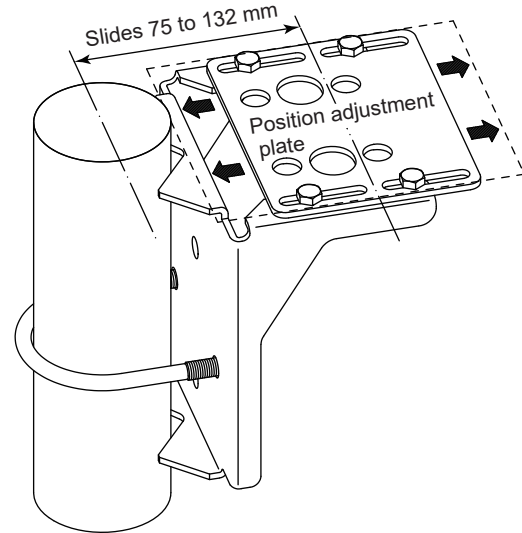

F0316.ai

Figure 3.6 Adjustable range of the plate

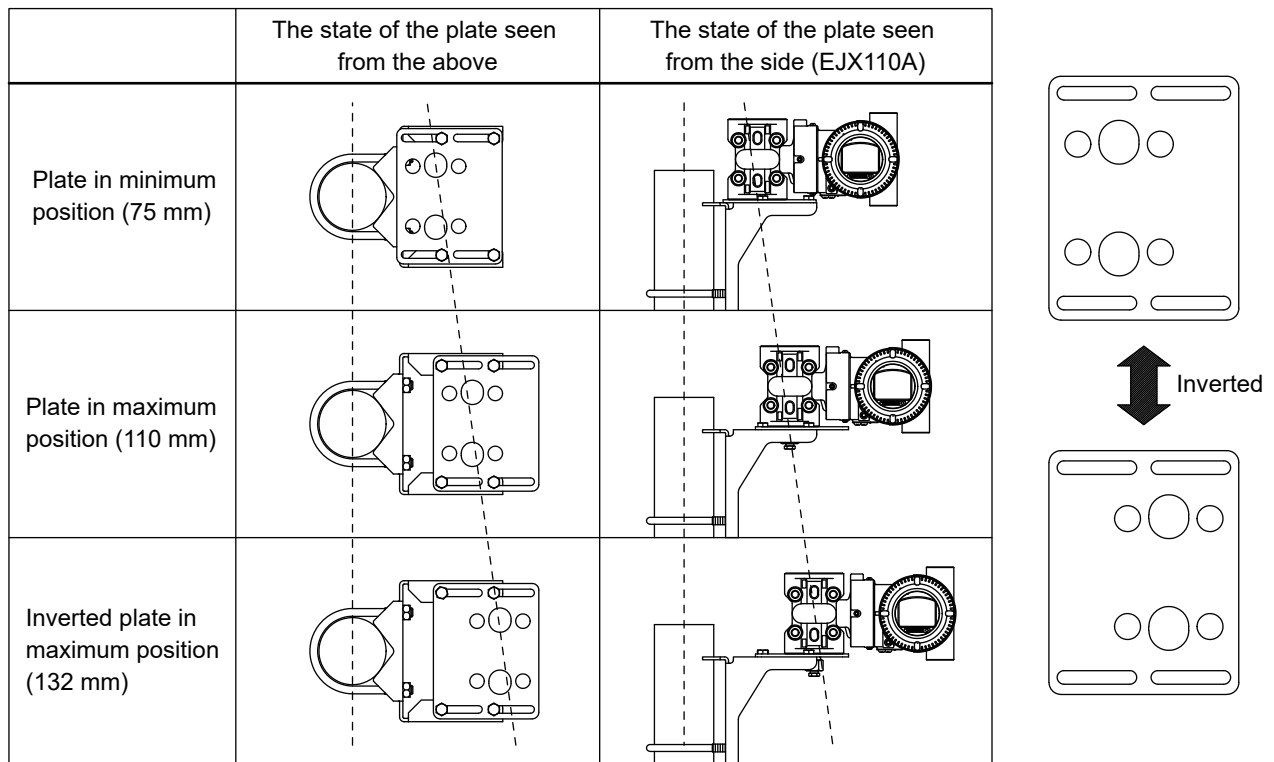

F0317.ai

Figure 3.7 The adjustable range by the mounting direction of the plate

3.2 Mounting the Diaphragm Seals



IMPORTANT

- Please use a gasket with an inside diameter (\varnothing d) that is greater than the diameter of the diaphragm seal. If a gasket with a smaller inside diameter is used, the diaphragm may not function correctly.
- During the diaphragm seal installation, ensure as far as possible that no seal liquid head pressure is applied to the diaphragm seals.
- Exercise care so as not to damage diaphragm surfaces. Since the diaphragm protrudes approx. 1 mm from the flange surface, do not place the pressure detector section face down on a surface as this can damage the diaphragm.
- Do not sharply bend or twist capillary tube or apply excessive stress to them.
- Never loosen the four bolts securing the cover flange or the screws at the joints between the capillary tube and cover flanges. If the seal liquid leaks, the transmitter cannot be used.

3.2.1 EJ□210□

The transmitter is mounted on a process using its high pressure side flange as shown in Figure 3.8. The customer should prepare the mating flange, gasket, stud bolts and nuts.

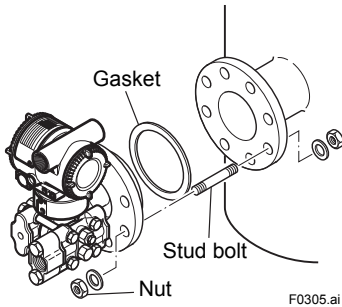

Figure 3.8 EJ□210□ Mounting



IMPORTANT

When measuring the liquid level of the tank, the minimum liquid level (zero point) must be set to a level at least 50 mm above the center of the high pressure side diaphragm seal (see Figure 3.10).

3.2.2 EJ□118□ and EJ□438□

Mount the diaphragm seals using the flanges as shown in Figure 3.9. The mating flange, gasket, bolts and nuts are to be procured by the customer.

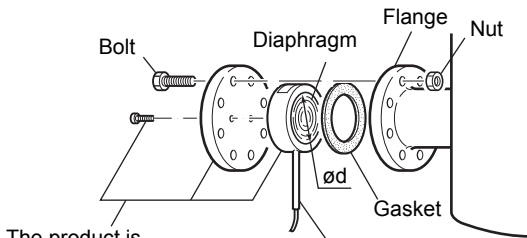

The product is shipped with these parts assembled.

Correctly install the diaphragm seals on the high and low pressure sides of the process (The label on each diaphragm seal is marked HIGH or LOW).

F0306.ai

Figure 3.9 Mounting the Diaphragm Seals

3.3 Diaphragm Seals Installation Consideration



IMPORTANT

- When measuring the liquid level of the tank, the minimum liquid level (zero point) must be set to a level at least 50 mm above the center of the high pressure side diaphragm seal (see Figure 3.10).
- Correctly install the diaphragm seals on the high and low pressure sides of the process, checking the label on each seal.
- To avoid measuring error duets temperature difference between the two diaphragm seals, capillary tube must be bound together. The capillary tube must be securely fixed to the tank wall to prevent movement by wind or vibration. If the capillary tube is too long, loosely coil the extra tube portion (coil diameter of 300 mm or more) and secure the coiled tube with a clamp.



IMPORTANT

Install the sealed diaphragm so that the shank positions downward.

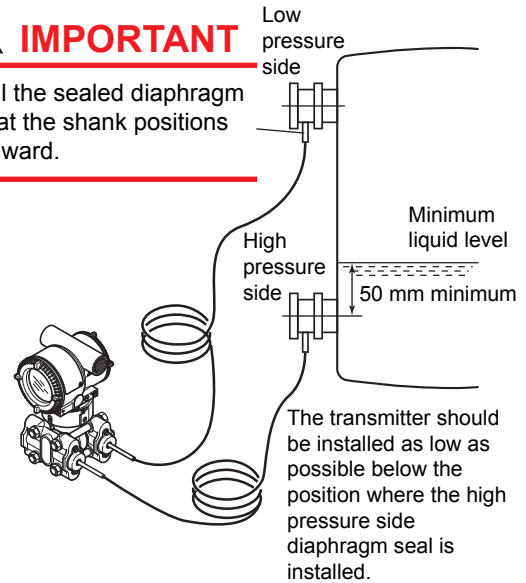

The transmitter should be installed as low as possible below the position where the high pressure side diaphragm seal is installed.

F0307.ai

Figure 3.10 Installing the Diaphragm Seals to a Tank



IMPORTANT

The transmitter should be installed at least 600 mm below the high pressure (HP) process connection to ensure a positive head pressure of fill fluid. Pay special attention to vacuum applications.

If it can not be installed at least 600 mm below the HP process connection, please use the equation below:

$$h = \frac{(P - P_0)}{ds} \times 0.102 \text{ [mm]}$$

h: Vertical height between the HP process connection and the transmitter (mm)

h ≤ 0: Install the transmitter at least h (mm) below the HP process connection

h > 0: Install the transmitter at most h (mm) above the HP process connection

P: Pressure in the tank (Pa abs)

P₀: Minimum working pressure limit of the transmitter (Pa abs) See below table.

[For fill fluid code A, B, C, D, E]

Wetted parts material code	Capillary length	Process connection size code		
		2, 8	3	4, W
SW	1 to 5m	6790	3190	
	6 to 10m	10030	3520	
SE	1 to 5m		6790	3190
	6 to 10m		10030	3520
SY	1 to 5m			3190
	6 to 10m			3520
HW	1 to 5m	19150	6140	
	6 to 10m		8290	
TW	1 to 5m	9620	3620	
	6 to 10m		4210	
UW	1 to 5m	9540	4750	
	6 to 10m		6050	

[For fill fluid code 1, 2, 4]

Wetted parts material code	Capillary length	Process connection size code		
		2, 8	3	4, W
SW	1 to 5m	2570	320	
	6 to 10m	4680	530	
SE	1 to 5m		2570	320
	6 to 10m		4680	530
SY	1 to 5m			320
	6 to 10m			530
HW	1 to 5m	10220	2050	
	6 to 10m		3450	
TW	1 to 5m	4270	570	
	6 to 10m		960	

ds: Specific gravity of fill fluid (at 25°C). See below table.

Fill fluid code	A, 1, 4	B	C, 2	D	E
ds: Specific gravity	1.07	0.94	1.09	1.90 to 1.92	1.09

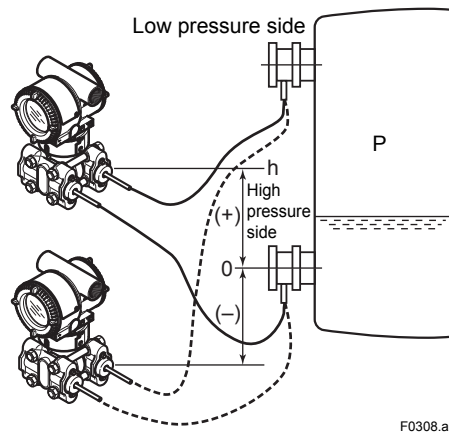

Figure 3.11 Example of Installation to Tank (Caution on Installation)

3.4 Mounting the Flushing Connection Ring

3.4.1 Mounting to Pressure Detector Section

The flushing connection ring is mounted to the pressure detector section as shown in Figure 3.12.

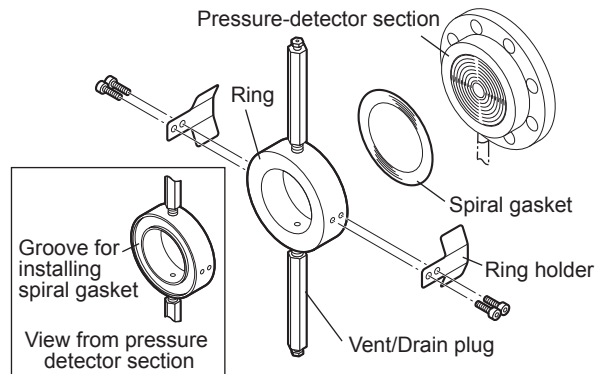
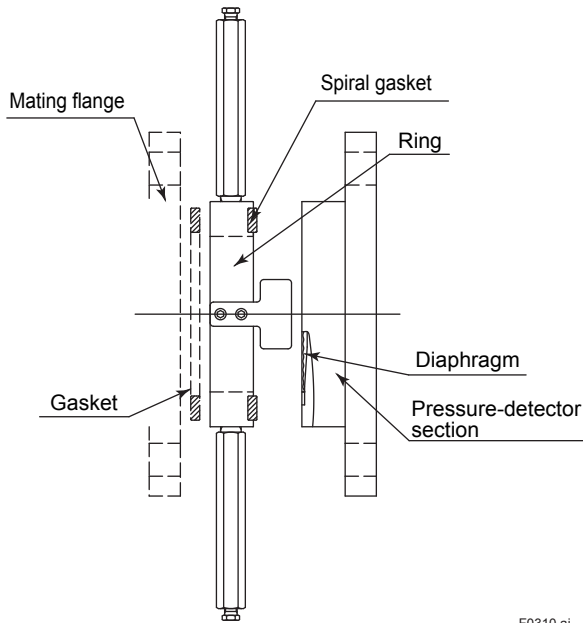

Figure 3.12 Mounting to Pressure Detector Section

- (1) Mount the ring holder on the ring and loosely tighten the mounting screws.
- (2) Place the spiral gasket in the ring groove. With the ring correctly aligned and flush with the face of the pressure detector, securely tighten each ring holder's mounting screws.
- (3) Position the ring so that the vent/drain plugs are aligned straight up and down.

3.4.2 Mounting to Process Flange

Tighten the bolts to completely close the gap between the ring and the pressure detector section.
The mating flange, gasket, stud bolts and nuts are to be procured by the customer.



F0310.ai

Figure 3.13 Mounting to Process Flange



IMPORTANT

- Confirm that there is no gap between the ring and the process-detector section after they are mounted on the process flange. A gap can lead to a sudden, explosive release of process fluids.
- When mounting or removing the ring, take care not to tilt the pressure detector downward as the ring can slip off and cause injury.
- When re-mounting the ring, use the new spiral gasket as shown in below table.

Table 3.1 Spiral Gasket for Pressure Detector Section Side*

Part number	Size	Description
F9350SV	ø100×ø120×t4.5	For 3-inch flange
F9970XF	ø100×ø120×t4.5	For 3-inch flange**
F9350ST	ø70×ø90×t4.5	For 2-inch flange
F9970XD	ø70×ø90×t4.5	For 2-inch flange**
F9346ZH	ø60×ø75×t4.5	For 1 1/2-inch flange
F9970XB	ø60×ø75×t4.5	For 1 1/2-inch flange**

*: Material; 316SST (Hoop), PTFE Teflon (Filler)

** : For oil-prohibited use (Option code: /K1, /K2, /K5, /K6)

3.5 Affixing the Teflon Film



IMPORTANT

The FEP Teflon option includes a teflon film and fluorinated oil. Before mounting the transmitter to the process flange, affix the teflon film as follows:

- 1) Position the diaphragm seal so that the diaphragm is in an upward position.
- 2) Pour the fluorinated oil on the diaphragm and gasket area covering it completely and evenly. Be careful not to scratch the diaphragm or change its shape.
- 3) Affix the teflon film over the diaphragm and gasket area.
- 4) Next, carefully inspect the cover and try to identify any entrapped air between the diaphragm and the teflon film. The air must be removed to ensure optimum performance. If air pockets are present, use your fingers to remove the air by starting at the center of the diaphragm and work your way out.
- 5) Position the gasket on the Teflon film.
- 6) Mount the transmitter onto the process flange.

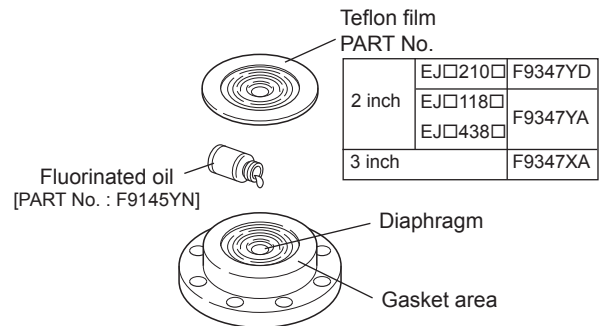

F0311.ai

Figure 3.14 Affixing the Teflon Film

3.6 Rotating Transmitter Section

The transmitter section can be rotated approximately 360° and can be fixed at any angle within the above range. (The direction of the rotation is depending on the configuration of the instrument.) Note that there is a stopper which prevents the transmitter section from being rotated more than 360°.

- 1) Remove the two setscrews that fasten the transmitter section and capsule assembly, using the Allen wrench.
- 2) Rotate the transmitter section slowly and stop it at designated position.
- 3) Tighten the two setscrews to a torque of 1.5 N·m.

WARNING

In the case of the explosion-proof/flameproof type transmitter, do not rotate the transmitter part in the hazardous area while the transmitter is energized.

IMPORTANT

Do not rotate the transmitter section more than the above limit.

Vertical impulse piping type

Pressure-detector section

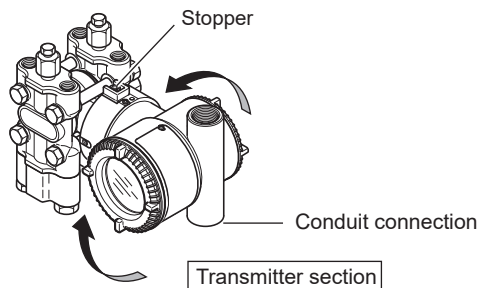

Horizontal impulse piping type

Transmitter section

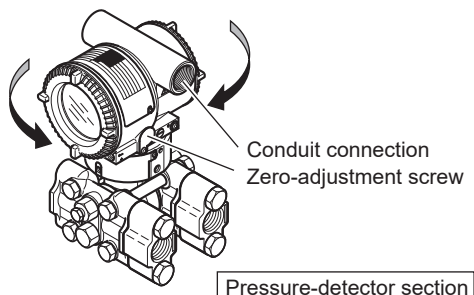

F0312.ai

Figure 3.15 Rotating Transmitter Section (Left Side High Pressure Type)

3.7 Changing the Direction of Integral Indicator

IMPORTANT

Always turn OFF power, release pressure and remove a transmitter to non-hazardous area before disassembling and reassembling an indicator.

An integral indicator can be installed in the following three directions.

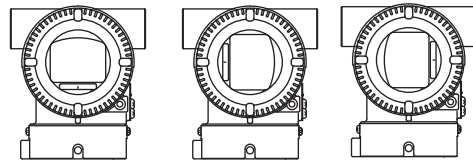

F0313.ai

Figure 3.16 Integral Indicator Direction

IMPORTANT

The terminal box cover is locked by an Allen head bolt (a shrouding bolt) on ATEX flameproof type transmitters. When the shrouding bolt is driven clockwise by an Allen wrench, it is going in and cover lock is released, and then the cover can be opened. When a cover is closed it should be locked by a shrouding bolt without fail. Tighten the shrouding bolt to a torque of 0.7 N·m.

- 1) Remove the cover.
- 2) While supporting the integral indicator with one hand, loosen its two mounting screws.
- 3) Dismount the LCD board assembly from the CPU assembly. When doing this, carefully pull the LCD board assembly straight forward so as not to damage the connector pins between it and the CPU assembly.
- 4) After rotating the LCD, align both the LCD board assembly and CPU assembly connectors and engage them.
- 5) Insert and tighten the two mounting screws.
- 6) Replace the cover.

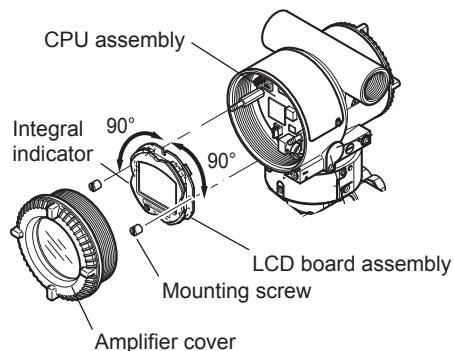

F0314.ai

Figure 3.17 Rotating Integral Indicator

4. Installing Impulse Piping

4.1 Impulse Piping Installation Precautions

The impulse piping that connects the process outputs to the transmitter must convey the process pressure accurately. If, for example, gas collects in a liquid-filled impulse line, or the drain of a gas-filled impulse line becomes plugged, it will not convey the pressure accurately. Since this will cause errors in the measurement output, select the proper piping method for the process fluid (gas, liquid, or steam). Pay careful attention to the following points when routing the impulse piping and connecting the impulse piping to a transmitter.

4.1.1 Connecting Impulse Piping to the Transmitter

(1) Check the High and Low Pressure Connections on the Transmitter (Figure 4.1)

Symbols “H” and “L” have been placed on the capsule assembly to indicate high and low pressure side. With differential pressure transmitters, connect the high pressure side impulse line to the “H” side, and the low pressure side impulse line to the “L” side. When option code /BS is specified, piping or process connector can't be connected to the low pressure side.

With gauge/absolute pressure transmitters, connect the impulse line to the ‘H’ side.

Differential Pressure Transmitter

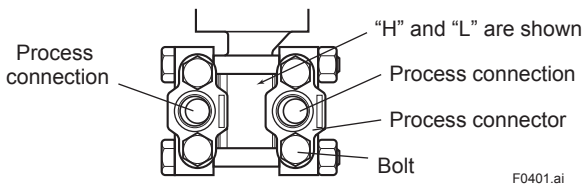

Figure 4.1 “H” and “L” Symbols on a Capsule Assembly

(2) Changing the Process Connector Piping Connections (for differential pressure transmitters)

The impulse piping connection distances can be changed between 51 mm, 54 mm and 57 mm by changing the orientation of the process connectors. This is convenient for aligning the impulse line with a process connectors.

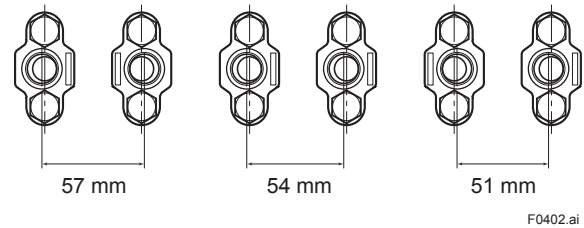

Figure 4.2 Process Connector Impulse Piping Connection Distances

(3) Tightening the Process Connector Mounting Bolts

After connecting an impulse line, tighten the process connector mounting bolts uniformly.



IMPORTANT

When installing a process connector, make sure that no foreign matter has adhered to the seal surface of the gasket (or O-ring) before assembly. If foreign matter adheres, it may lead to leaks. In the case of O-rings, it is known that the sealing performance can be improved by applying grease. If grease is not used, make sure that no foreign matter is attached.

(4) Removing the Impulse Piping Connecting Port Dustproof Cap

The impulse piping connecting port on the transmitter may be covered with a plastic cap to keep out dust. This cap must be removed before connecting the line. (Be careful not to damage the threads when removing this cap. Never insert a screwdriver or other tool between the cap and port threads to remove the cap.)

(5) Connecting the Transmitter and 3-Valve Manifold (for differential pressure transmitters)

A 3-valve manifold consists of two stop valves to block process pressure and an equalizing valve to equalize the pressures on the high and low pressure sides of the transmitter. Such a manifold makes it easier to disconnect the transmitter from the impulse piping, and is convenient when adjusting the transmitter zero point.

There are two 3-valve manifold types: the pipe-mounting type and the direct-mounting type; care should be taken with respect to the following points when connecting the manifold to the transmitter.

■ Pipe-Mounting Type 3-Valve Manifold

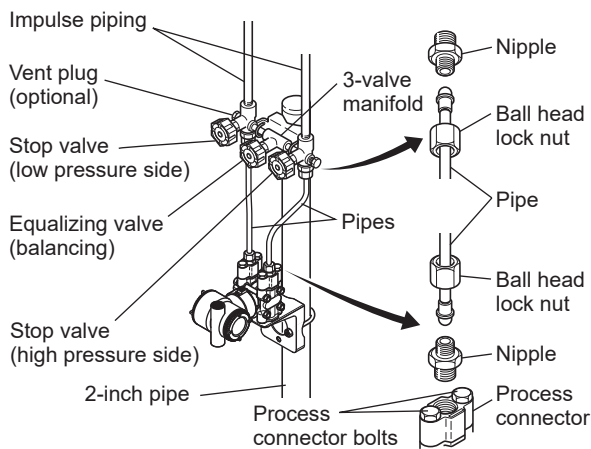

Figure 4.3 3-Valve Manifold (Pipe-Mounting Type)

- 1) Screw nipples into the connection ports on the transmitter side of the 3-valve manifold, and into the impulse piping connecting ports on the process connectors. (To maintain proper sealing, wind sealing tape around the nipple threads.)
- 2) Mount the 3-valve manifold on the 2-inch pipe by fastening a U-bolt to its mounting bracket. Tighten the U-bolt nuts only lightly at this time.
- 3) Install the pipe assemblies between the 3-valve manifold and the process connectors and lightly tighten the ball head lock nuts. (The ball-shaped ends of the pipes must be handled carefully, since they will not seal properly if the ball surface is scratched or otherwise damaged.)
- 4) Now tighten the nuts and bolts securely in the following sequence:
 Process connector bolts → transmitter-end ball head lock nuts → 3-valve manifold ball head lock nuts → 3-valve manifold mounting bracket U-bolt nuts

■ Direct-Mounting Type 3-Valve Manifold

- 1) Mount the 3-valve manifold on the transmitter. (When mounting, use the two gaskets and the four bolts provided with the 3-valve manifold. Tighten the bolts evenly.)
- 2) Mount the process connectors and gaskets on the top of the 3-valve manifold (the side on which the impulse piping will be connected.)

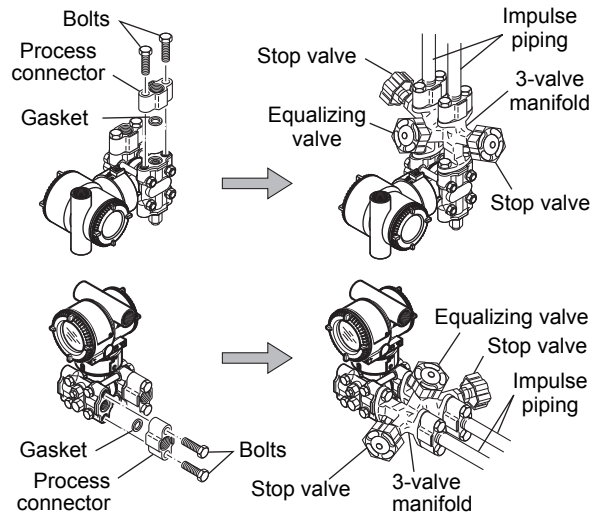

Figure 4.4 3-Valve Manifold (Direct-Mounting Type)



NOTE

After completing the connection of the transmitter and 3-valve manifold, be sure to CLOSE the low pressure and high pressure stop valves, OPEN the equalizing valve, and leave the manifold with the equalizing valve OPEN.

You must do this in order to avoid overloading the transmitter from either the high or the low pressure side when beginning operation.

4.1.2 Routing the Impulse Piping

(1) Process Pressure Tap Angles

If condensate, gas, sediment or other extraneous material in the process piping gets into the impulse piping, pressure measurement errors may result. To prevent such problems, the process pressure taps must be angled as shown in Figure 4.5 according to the kind of fluid being measured.



NOTE

- If the process fluid is a gas, the taps must be vertical or within 45° either side of vertical.
- If the process fluid is a liquid, the taps must be horizontal or below horizontal, but not more than 45° below horizontal.
- If the process fluid is steam or other condensing vapor, the taps must be horizontal or above horizontal, but not more than 45° above horizontal.

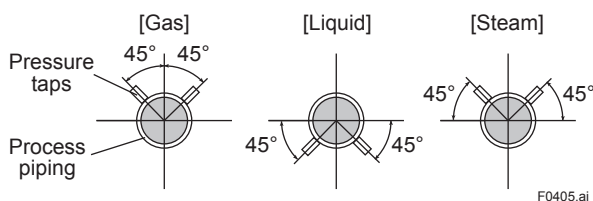

Figure 4.5 Process Pressure Tap Angle (For Horizontal Piping)

(2) Position of Process Pressure Taps and Transmitter

If condensate (or gas) accumulates in the impulse piping, it should be removed periodically by opening the drain (or vent) plugs. However, this will generate a transient disturbance in the pressure measurement, and therefore it is necessary to position the taps and route the impulse piping so that any extraneous liquid or gas generated in the leadlines returns naturally to the process piping.

- If the process fluid is a gas, then as a rule the transmitter must be located higher than the process pressure taps.
- If the process fluid is a liquid or steam, then as a rule the transmitter must be located lower than the process pressure taps.

(3) Impulse Piping Slope

The impulse piping must be routed with only an upward or downward slope. Even for horizontal routing, the impulse piping should have a slope of at least 1/10 to prevent condensate (or gases) from accumulating in the pipes.

(4) Temperature Difference Between Impulse Piping (for differential pressure transmitters)

If there is a temperature difference between the high and low impulse lines, the density difference of the fluids in the two lines will cause an error in the measurement pressure. When measuring flow, impulse lines must be routed together so that there is no temperature difference between them.

(5) Condensate Pots for Steam Flow Measurement (for differential pressure transmitters)

If the liquid in the impulse piping repeatedly condenses or vaporizes as a result of changes in the ambient or process temperature, this will cause a difference in the fluid head between the high pressure and low pressure sides. To prevent measurement errors due to these head differences, condensate pots are used when measuring steam flow.

(6) Preventing Wind Speed Effects in Very Low Differential Pressure Measurement (for differential pressure transmitters)



IMPORTANT

When using a differential pressure transmitter to measure very low pressures (draft pressure), the low pressure connection port is left open to atmospheric pressure (the reference pressure).

Any wind around the differential pressure transmitter will therefore cause errors in the measurement. To prevent this, it will be necessary either to enclose the transmitter in a box, or to connect a impulse line to the low pressure side and insert its end into a wind excluding pot (cylindrical with a base plate).

(7) Preventing Freezing

If there is any risk that the process fluid in the impulse piping or transmitter could freeze, use a steam jacket or heater to maintain the temperature of the fluid.



NOTE

After completing the connections, close the valves on the process pressure taps (main valves), the valves at the transmitter (stop valves), and the impulse piping drain valves, so that condensate, sediment, dust and other extraneous material cannot enter the impulse piping.

4.2 Impulse Piping Connection Examples

Figure 4.6, 4.7, and 4.8 shows examples of typical impulse piping connections. Before connecting the transmitter to the process, study the transmitter installation location, the process piping layout, and the characteristics of the process fluid (corrosiveness, toxicity, flammability, etc.), in order to make appropriate changes and additions to the connection configurations.

Note the following points when referring to these piping examples.

- If the impulse line is long, bracing or supports should be provided to prevent vibration.
- The impulse piping material used must be compatible with the process pressure, temperature, and other conditions.
- A variety of process pressure tap valves (main valves) are available according to the type of connection (flanged, screwed, welded), construction (globe, gate, or ball valve), temperature and pressure. Select the type of valve most appropriate for the application.

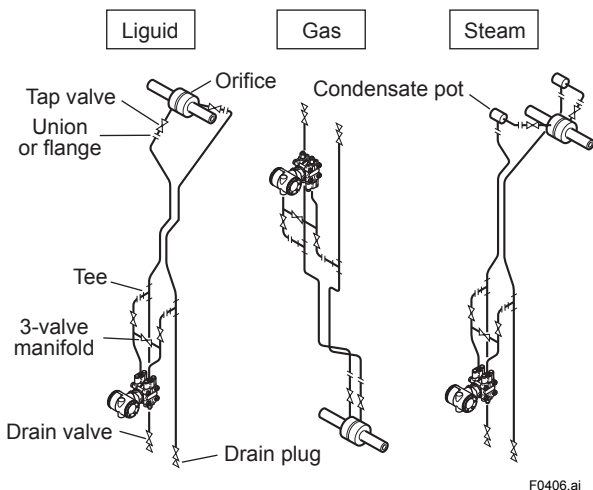

Figure 4.6 Impulse Piping Connection Examples (for differential pressure transmitters)

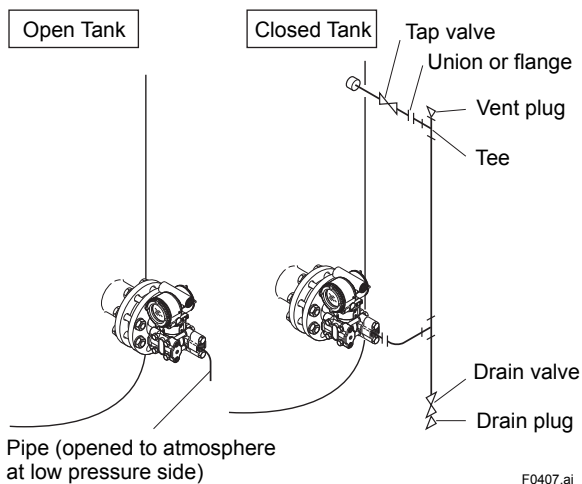

Figure 4.7 Impulse Piping Connection Examples (EJ□210□)

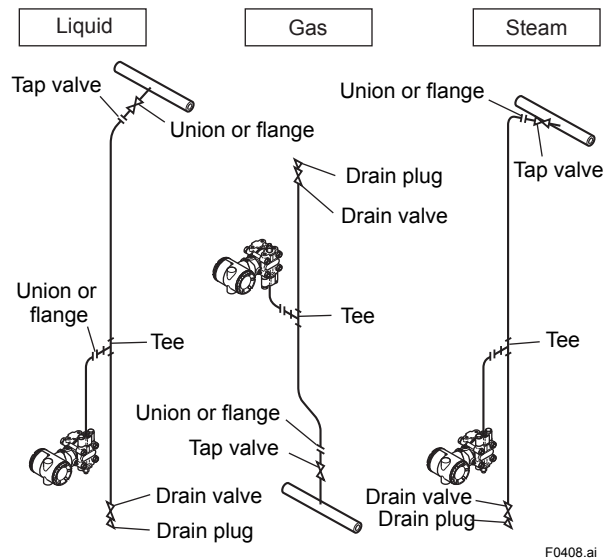

Figure 4.8 Impulse Piping Connection Examples (for gauge/absolute pressure transmitters)

4.3 Process Piping Installation Precautions (EJ□115□)

4.3.1 Connecting Process Piping to the Transmitter

(1) Confirming the Process Fluid Flow Direction

The mark “←” on the manifold indicates the direction in which the process fluid is flowed (from right to left). When connecting the process piping to the process connector, confirm the process fluid flow direction.

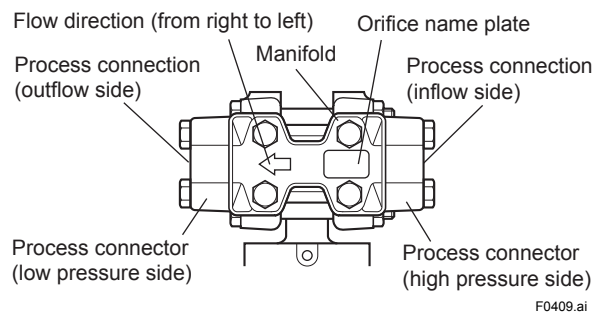

Figure 4.9 Manifold and Flow Direction Indication

(2) Tightening the Process Connector Mounting Bolts

The transmitter is shipped with the process connector mounting bolts only loosely tightened. After connecting the process piping, tighten these bolts uniformly to prevent leaks with a torque of 39 to 49 N·m {4 to 5 kgf·m}.



IMPORTANT

When installing a process connector or manifold, make sure that no foreign matter has adhered to the seal surface of the gasket before assembly. If foreign matter adheres, it may lead to leaks.

(3) Removing the Process Connector Port Dustproof Cap

The process connector port threads may be covered with a plastic cap to exclude dust. This cap must be removed before connecting the piping. (Be careful not to damage the threads when removing this cap. Never insert a screwdriver or other tool between the cap and port threads to remove the cap.)

4.3.2 Routing the Process Piping

(1) Relationship between Process Fluid and Manifold Locations (For the vertical impulse piping type)

If condensate (or gas) generated in the process piping were allowed to accumulate, then it would be necessary to remove it periodically by opening the drain (or vent) plug. However, this would generate a transient disturbance in the pressure measurement. Therefore, the process piping must be routed so that any condensate (or gas) generated in the process piping will not accumulate in the pressure-sensing assembly of the transmitter.



NOTE

- If the process fluid is a gas, then as a rule the manifold must be located at the downside of the pressure-sensing assembly.
- If the process fluid is a liquid, then as a rule the manifold must be located at the upside of the pressure-sensing assembly.

(2) Pipe Size for Process Piping

Use a 15 mm (1/2-inch) pipe for process piping connection to the process connector.

(3) Preventing Freezing

If there is any risk that the process fluid in the transmitter pressure-sensing assembly could freeze or solidify, use a steam jacket or heater to maintain the temperature of the fluid.

(4) Process Piping Connection Examples

Figure 4.10 shows examples of typical process piping connections. Before connecting the transmitter to the process, study the transmitter installation location, the process piping layout, and the characteristics of the process fluid (corrosiveness, toxicity, flammability, etc.), in order to make appropriate changes and additions to the connection configurations.

Note the following points when referring to these piping examples.

- The process piping material used must be compatible with the process pressure, temperature, and other conditions.
- A variety of process piping-mounted stop valves are available according to the type of connection (flanged, screwed, welded), construction (globe, gate, or ball valve), temperature and pressure. Select the type of valve most appropriate for the application.

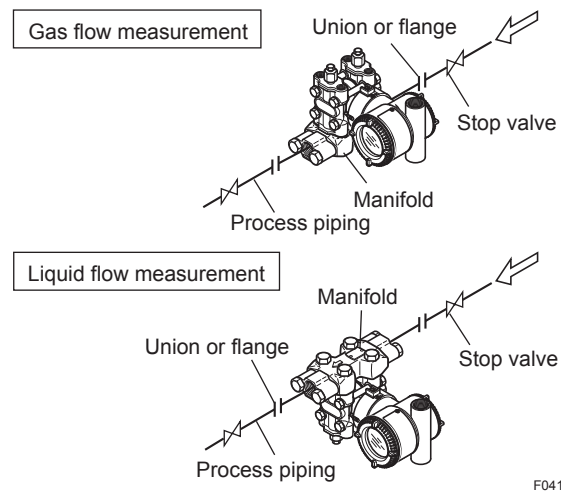

Figure 4.10 Process Piping Connection Examples (EJ□115□)

F0410.ai

5. Wiring



NOTE

For FOUNDATION Fieldbus, PROFIBUS PA, and Mod bus communication types, please refer to each communication manual.

5.1 Wiring Precautions



IMPORTANT

- Lay wiring as far as possible from electrical noise sources such as large capacity transformers, motors, and power supplies.
- Remove electrical connection dust cap (plug) before wiring.
- All threaded parts must be treated with waterproofing sealant. (A non-hardening silicone group sealant is recommended.)
- To prevent noise pickup, do not pass signal and power cables through the same ducts.
- Explosion-protected instruments must be wired in accordance with specific requirements (and, in certain countries, legal regulations) in order to preserve the effectiveness of their explosion-protected features.
- The terminal box cover is locked by an Allen head bolt (a shrouding bolt) on ATEX flameproof type transmitters. When the shrouding bolt is driven clockwise using an Allen wrench, it goes in. The cover lock can then be released and the cover can be opened by hand.
When a cover is closed it should be locked by a shrouding bolt without fail. Tighten the shrouding bolt to a torque of 0.7 N·m.

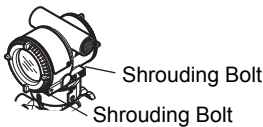

F0501.ai

Figure 5.1 Shrouding Bolt

- Plug and seal an unused conduit connection.

5.2 Connections of External Wiring to Terminal Box

• Terminal Configuration

RTD cable connection*

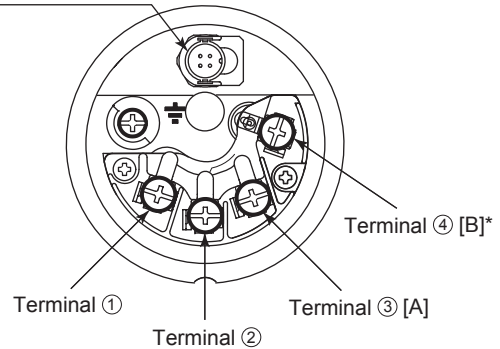

*For EJX9□□A only.

F0527.ai

• Terminal Wiring for 4 to 20 mA output

SUPPLY +	①] Power supply and output terminals
-	②	
CHECK +	③] External indicator (ammeter) terminals ^{*1,2}
or -	②	
ALARM +	③] Status contact output terminals ²
-	②	
		⏏ Ground terminal

*1: When using an external indicator or check meter, the internal resistance must be 10 Ω or less. A check meter or indicator cannot be connected when /AL option is specified.

*2: Not available for FOUNDATION Fieldbus and PROFIBUS PA communication types.

• Terminal Wiring for 1 to 5 V output

SUPPLY +	①] Power supply terminals
-	②	
VOUT +	③] 1 to 5 V DC with HART communication terminals
-	②	
		⏏ Ground terminal

• Terminal Wiring for 4 to 20 mA output [EJX9□□A]

SUPPLY +	①] Power supply and output terminals
-	②	
CHECK +	③] External indicator (ammeter) terminals ^{*1,2}
-	②	
PULSE +	④] Pulse or status contact output terminals ^{*2}
-	②	
		⏏ Ground terminal

*1: When using an external indicator or check meter, the internal resistance must be 10Ω or less.

*2: Not available for FOUNDATION Fieldbus communication type.

F0528.ai

Figure 5.2 Terminal

5.2.1 Power Supply Wiring Connection



IMPORTANT

Connecting with the commercial AC power supply will damage the device. Be sure to use the DC power supply in the predetermined range.

Connect the power supply wiring to the SUPPLY + and – terminals.

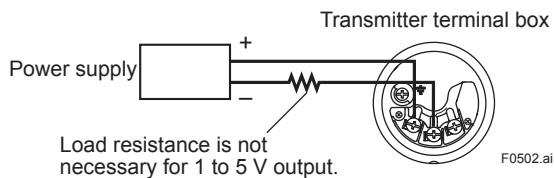

Figure 5.3 Power Supply Wiring Connection

5.2.2 Configuration Tool Connection

■ 4 to 20 mA output, BRAIN / HART

Connect the configuration tool to the SUPPLY + and – terminals. (Use hooks.)

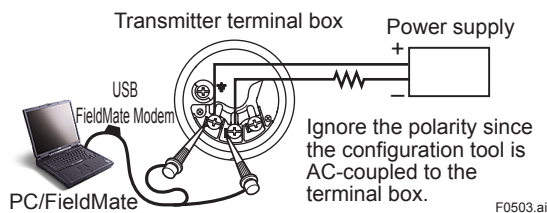

Figure 5.4 Configuration Tool Connection

■ 1 to 5 V output, HART

Connect the HART communicator or configuration tool to the SUPPLY - and VOUT (+) terminals. (Use hooks.)

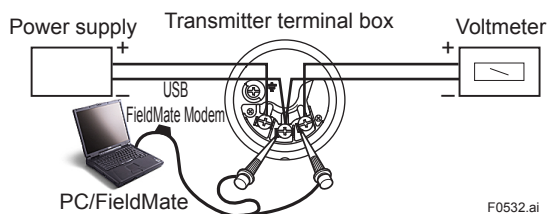

Figure 5.5 Four wire connection

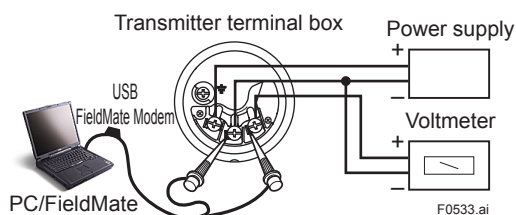

Figure 5.6 Three wire connection

5.2.3 Status Output Connection

When option code /AL is specified, connect the external wiring as shown in Figure 5.7.

To configure and activate the process alarm function and status output, it is necessary to set some parameters. Refer to each communication manual for procedures.

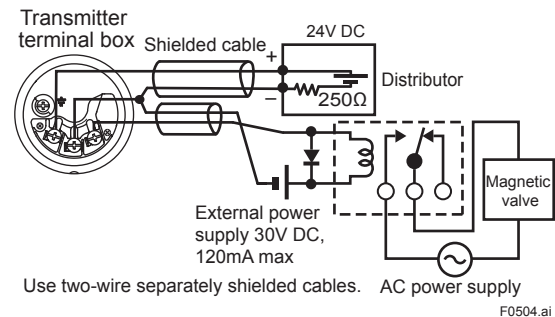
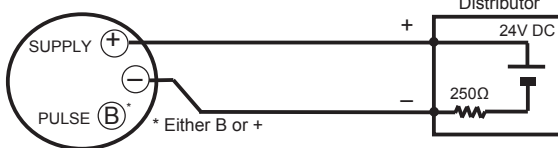
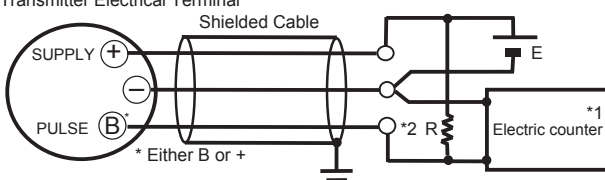
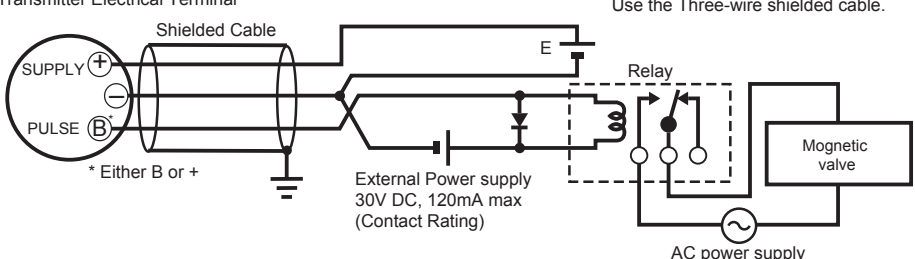

Figure 5.7 Status Output Connection

5.2.4 Connection Example for EJX910A and EJX930A

Table 5.1 The connection example for simultaneous analog and pulse and alarm, status output. (For HART protocol type)

Connection	Description
<p>Analog Output</p> <p>In this case, Communication is possible (up to a distance of 2km when a CEV cable is used.)</p>	<p>Transmitter Electrical Terminal</p>  <p>Distributor</p> <p>24V DC</p> <p>250Ω</p> <p>* Either B or +</p>
<p>Pulse Output</p> <p>In this case, No communication is possible.</p>	<p>Transmitter Electrical Terminal</p> <p>Use the Three-wire shielded cable.</p>  <p>Shielded Cable</p> <p>30V DC</p> <p>250Ω</p> <p>* Either B or +</p> <p>Electric counter *1</p>
<p>Status Output</p> <p>In this case, No communication is possible.</p>	<p>Transmitter Electrical Terminal</p> <p>Use the Three-wire shielded cable.</p>  <p>Shielded Cable</p> <p>30V DC, 120mA max (Contact Rating)</p> <p>* Either B or +</p> <p>Relay</p> <p>Magnetic valve</p> <p>AC power supply</p>
<p>Simultaneous Analog -Pulse Output *3</p> <p>Example 1 In this case, Communication is possible (up to a distance of 2km when a CEV cable is used).</p> <p>Example 2 In this case, Communication is possible (up to a distance of 200m when a CEV cable is used) and R = 1kΩ).</p> <p>Example 3 In this case, No communication is possible (when shielded cable is not used).</p>	<p>When analog and pulse output are used, the length of communication line is subjected to wiring conditions. Refer to example 1 to 3.</p> <p>Distributor (or communication medium : ex. EP card)</p> <p>24V DC</p> <p>250Ω</p> <p>*2 R</p> <p>E(10.5 to 30V DC) Counting input</p> <p>Common</p> <p>Electric counter *1 (or communication medium : ex. EP card)</p> <p>For the shielded cables in this example of flowmeter installation, use two-wire separately shielded cables.</p> <p>This supply voltage requires a power source with a maximum output current of no less than E/R.</p> <p>Transmitter Electrical Terminal</p> <p>Shielded Cable</p> <p>250Ω</p> <p>R *2</p> <p>E(16.4 to 30V DC)</p> <p>Recorder or other instrument</p> <p>Counting input</p> <p>Common</p> <p>Electric counter *1</p> <p>For the shielded cables in this example of flowmeter installation, use two-wire separately shielded cables.</p> <p>This supply voltage requires a power source with a maximum output current of no less than E/R+25mA.</p> <p>The supply voltage requires output impedance no more than 1/1000 of R (load resistance).</p> <p>Transmitter Electrical Terminal</p> <p>Shielded Cable</p> <p>250Ω</p> <p>R *2</p> <p>E(16.4 to 30V DC)</p> <p>Recorder or other instrument</p> <p>Counting input</p> <p>Common</p> <p>Electric counter *1</p> <p>This supply voltage requires a power source with a maximum output current of no less than E/R+25mA.</p> <p>* Either B or +</p> <p>Transmitter Electrical Terminal</p>
<p>The range of load resistance R for the pulse output.</p>	<p>The load resistance of pulse output should be used to 1kΩ, 2W.</p> <p>If no translation of the pulse output possible by the cable length or the frequency of the pulse output, the load resistance should be selected by calculation as shown below.</p> $\frac{E (V)}{120} \leq R (k\Omega) \leq \frac{0.1}{C (\mu F) \times f (kHz)}$ <p>Example of CEV cable capacitance ≒ 0.1μF/km</p> $P (mW) = \frac{E^2 (V)}{R (k\Omega)}$ <p>Where E = Supply voltage (V) f = Frequency of pulse output (kHz) R = Value of load resistance (kΩ) C = Cable capacitance (μF) P = Power ratio of the load resistance (mW)</p>

F0531.ai

*1: To avoid the influence of external noise, use an electric counter which fits to the pulse frequency.

*2: Resistor is not necessary in case of an electric counter which can receive contact pulse signal directly.

*3: When using analog and pulse output simultaneously, the HART communication may be influenced by noise comparing analog output only. Take countermeasure for noise shown above, e.g. use shield cable etc.

5.2.5 External Temperature Connection (for EJX910A and EJX930A)

Connect the RTD cable assembly to the Juck Terminal.

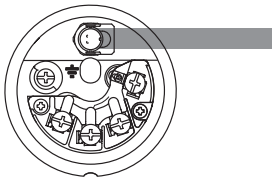

F0505.ai

Figure 5.8 External Temperature Connection

5.3 Wiring

5.3.1 Loop Configuration

Since the DPharp uses a two-wire transmission system for 4 to 20 mA output, signal wiring is also used as power wiring.

DC power is required for the transmitter loop. The transmitter and distributor are connected as shown below. For details of the power supply voltage and load resistance, see Section 5.6.

For 1 to 5 V output, three or four wire system is used. See (4).

(1) General-use Type and Flameproof Type (4 to 20 mA output)

- Analog Output

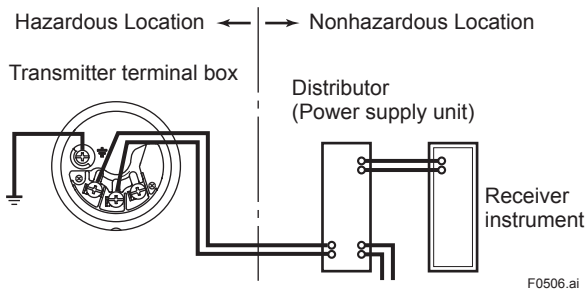

F0506.ai

Figure 5.9 Connection between Transmitter and Distributor

- Pulse output and Alarm, Status Output or Simultaneous Analog-Pulse Output (for EJX910A and EJX930A)

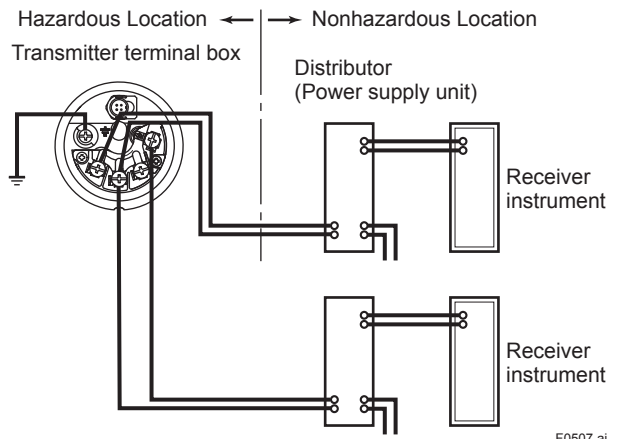

F0507.ai

Figure 5.10 Connection between Transmitter and Distributor

(2) Intrinsically Safe Type (4 to 20 mA output)

With the intrinsically safe type, a safety barrier must be included in the loop.

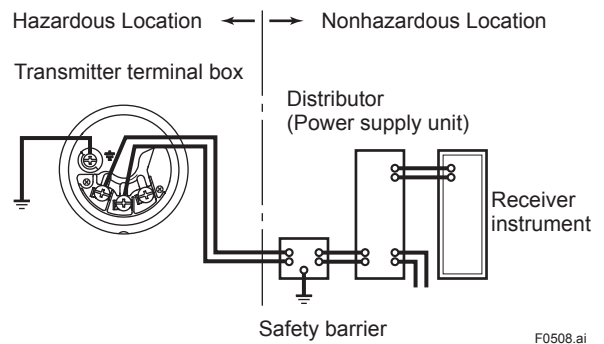

F0508.ai

Figure 5.11 Connection between Transmitter and Distributor

(3) Intrinsically Safe Type (for EJX910A and EJX930A)

- Analog Output

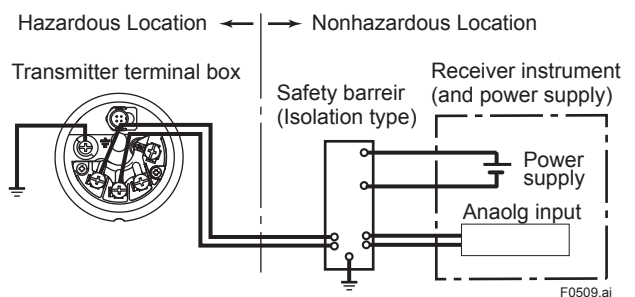

F0509.ai

• **Simultaneous Analog-Pulse Output**

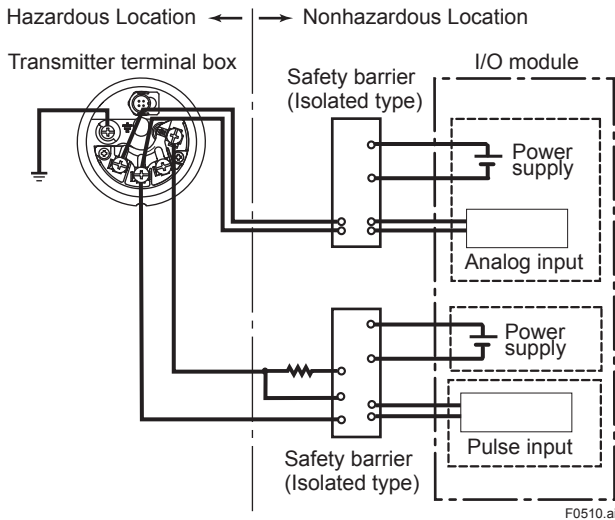

Figure 5.12 Connection between Transmitter, barrier and receiver

- Four wire connection
Fasten the negative side wiring of both power supply and signal line to the SUPPLY - terminal.

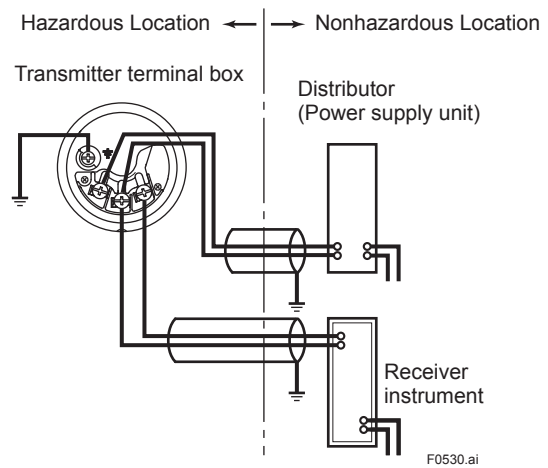

Figure 5.14 Connection between Transmitter, Distributor and Receiver

(4) 1 to 5 V output

Either three or four wire system can be used. Power supply line and 1 to 5 V signal line commonly use the SUPPLY - terminal.



With three wire connection, the cable length may affect the measurement accuracy of the output signal. In either three-wire or four-wire connection, recommended wiring distance is 200 m or less, and the use of shielded cable is recommended.

- Three wire connection
A negative wiring shall be commonly used for power supply and signal line.

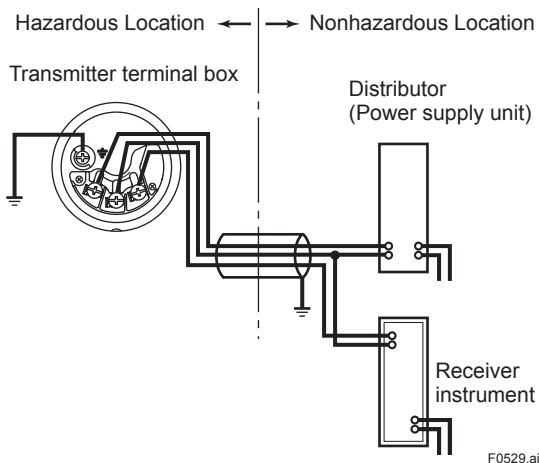

Figure 5.13 Connection between Transmitter, Distributor and Receiver

5.3.2 Wiring Installation

(1) General-use Type and Intrinsically Safe Type

With the cable wiring, use a metallic conduit or waterproof glands.

- Apply a non-hardening sealant to the terminal box connection port and to the threads on the flexible metal conduit for waterproofing.

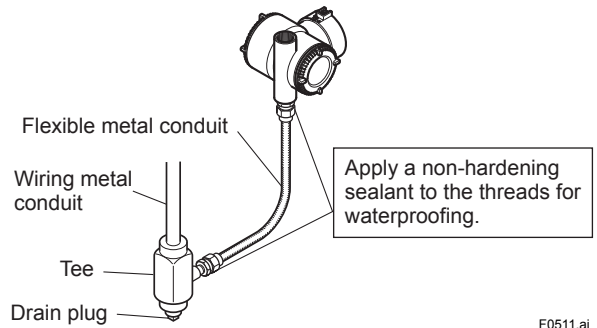

Figure 5.15 Typical Wiring Using Flexible Metal Conduit

(2) Flameproof Type

Wire cables through a flameproof packing adapter, or use a flameproof metal conduit.

- Wiring cable through flameproof packing adapter.
 - Apply a non-hardening sealant to the terminal box connection port and to the threads on the flameproof packing adapter for waterproofing.

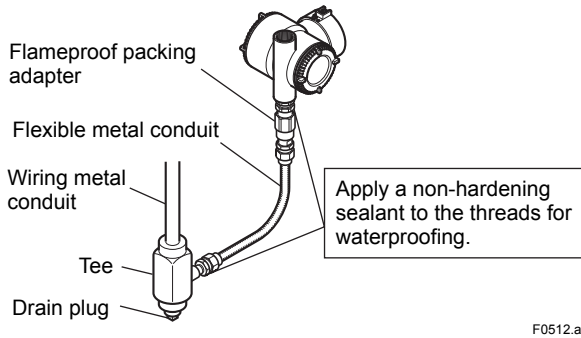

Figure 5.16 Typical Cable Wiring Using Flameproof Packing Adapter

- Flameproof metal conduit wiring
 - A seal fitting must be installed near the terminal box connection port for a sealed construction.
 - Apply a non-hardening sealant to the threads of the terminal box connection port, flexible metal conduit and seal fitting for waterproofing.

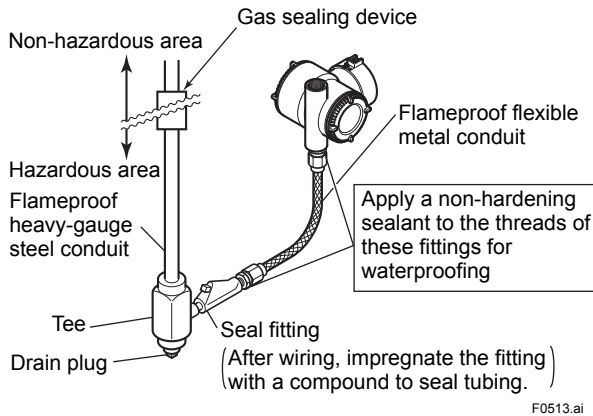

Figure 5.17 Typical Wiring Using Flameproof Metal Conduit



IMPORTANT

When electrical connection code “7” or “C” is specified, the blanking element at the electrical connection port is provided with sealing tape applied. As using sealing tape is prohibited for Ex “d” entry devices by the requirements of IEC 60079-14, remove the sealing tape and apply appropriate seal to the blanking element in accordance with IEC 60079-14, if the instrument is used as Ex “d” equipment.

5.4 RTD Cable Connection (EJX910A/EJX930A)

Connection of the RTD cable is always required to measure external temperature. Follow the procedures below to connect and disconnect a cable when a cable gland or a conduit is used.

5.4.1 Connecting Shielded Cable with Cable Gland (External temperature input code: -1, -2, -3, and -4)



CAUTION

- When the option code: PF22, PF23, NF2, NF21, UF1, GF11, GF12, GU11 or GU12 is selected, cable glands for RTD cable are not attached.
- For these option, prepare the cable gland conform to the cable of $\varnothing 8.5\text{mm}$ diameter. In the case to insert the RTD cable into cable gland from the side of RTD connector, inner diameter of the cable gland must be larger than $\varnothing 13\text{mm}$. If the inner diameter of selected cable gland is smaller than $\varnothing 13\text{mm}$, insert the RTD cable from the opposite side of the RTD connector before laying RTD cable.

- RTD connection components: EJX multivariable transmitter, two cable glands, and RTD cable Two cable glands are attached.

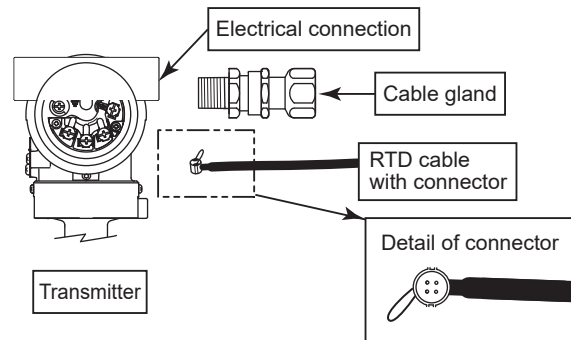

F0514.ai

- Magnified view of the RTD connector in the transmitter's terminal box.

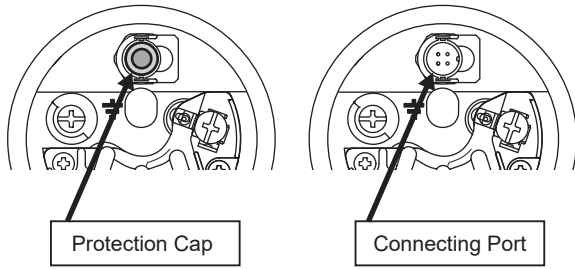

F0515.ai

The RTD cable connecting port is covered with a cap to keep out dust. The cap should not be removed until you are ready to install the cable.

CAUTION

Input/output signal is non-isolated.
Do not turn on power supply until you complete all the wiring work.

■ **In the case of electrical connection code 2 (1/2NPT female) or 4 (M20 female).**

- Components for the cable gland
The cable gland assembly consists of an entry, seal, running coupler, and backnut. Confirm that the seal is attached inside the entry and that the thread size of the cable gland is the same as that for the RTD electrical connection.

1/2NPT Type

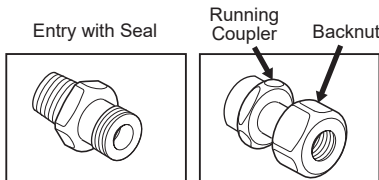

M20 Type

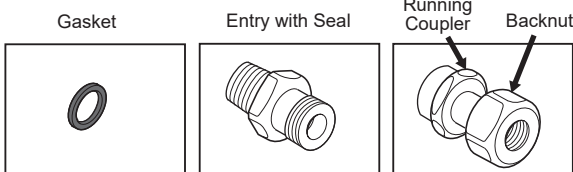

F0516.ai

Procedure

- (1) Pass the RTD cable through the cable gland from the cable end of the wire rods side (opposite side of RTD connector).

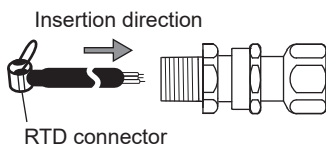

F0517.ai

- (2) Remove the protection cap over the transmitter electrical connection and install the entry on the electrical connection. Note that a non-hardening sealant should be applied to the threads for a 1/2 NPT connection and a gasket should be used for an M20 connection.

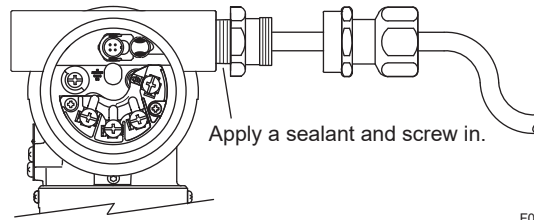

F0518.ai

- (3) Insert the RTD cable and firmly plug its connector into the connecting port in the transmitter's terminal box.

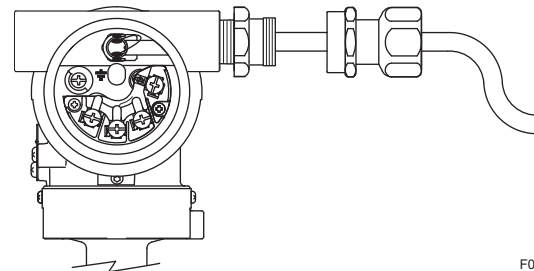

F0519.ai

- (4) Align the running coupler on the entry.

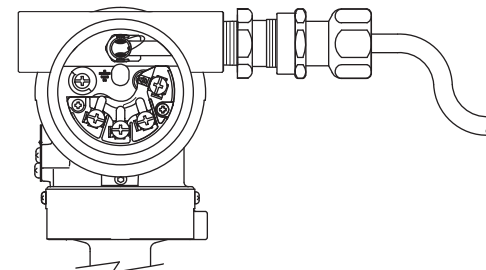

F0520.ai

- (5) Turn the running coupler until the seal in the entry comes into contact with the RTD cable.

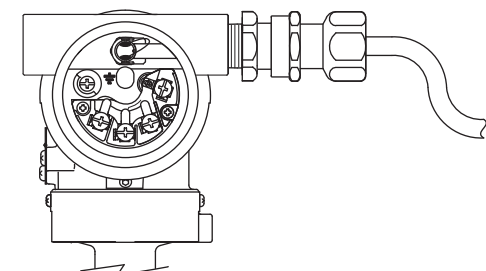

F0521.ai

- (6) Rotate the running coupler another half turn to securely tighten the seal on the RTD cable.
- (7) Use a protection conduit, if necessary. In this case, insert the cable through the conduit and attach it to the Backnut.

CAUTION

After the cable is secured as explained above, do not tighten the running coupler any further; to do so could damage the RTD connection.
Do not pull the cable or subject it to excessive mechanical shock.

In the case of electrical connection code F (G1/2 female).

- Components for the cable gland
The cable gland assembly consists of an adapter body, packing box, rubber packing, washer, gland, clamp ring, clamp nut, union coupling, and union cover.
Refer to (2) and (3) shown below.
RTD cable gland is accompanied by two kinds of rubber packing.
Since the outside diameter of the RTD cable is 8.5 mm, use the rubber packing with identification mark "16 8-10" on it.

NOTE

The RTD cable can not let through the cable gland from the connector side.
Insert the cable through the cable gland from the wire rods side (opposite side of RTD connector) before laying the cable.

Procedure

- (1) Disassemble the cable gland: loosen the all parts
- (2) Remove the protection cap on the RTD electrical connection and RTD connecting port, and screw the adapter body to the RTD electrical connection. Screw the adapter body into the RTD electrical connection until the O-ring touches the RTD electrical connection (at least 6 full turns), and firmly tighten the lock nut by the wrench.

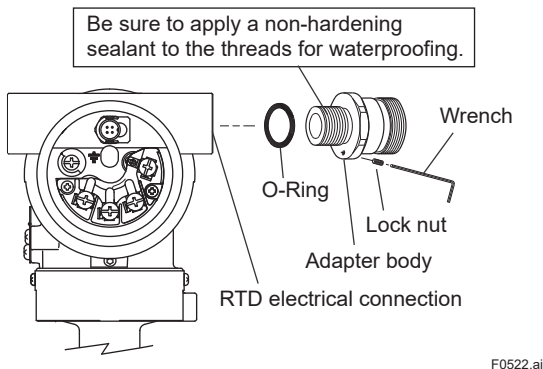

F0522.ai

- (3) Insert the RTD cable in order of a packing box, rubber packing, washer, gland, clamp ring, clamp nut, union coupling, union cover from the cable end of the wire rods side (opposite side of RTD connector). Since the internal diameter of rubber packing has restriction, RTD connector can not pass through it, please keep this order.

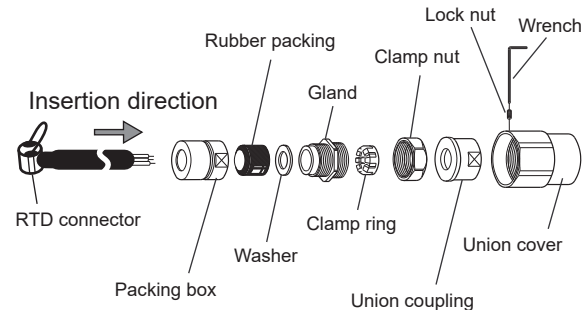

F0523.ai

- (4) Secure the RTD cable to the packing box by screwing the gland into the packing box at the position where the distance from the connector tip of the RTD cable to the packing box will be 56.5 ± 1 mm. Tighten approximately 1 more turn surely after the cable can not move. The quantity of this tightening is very important. It leads to wiring disconnection fault when tighten too much. After that, tighten the clamp nut.

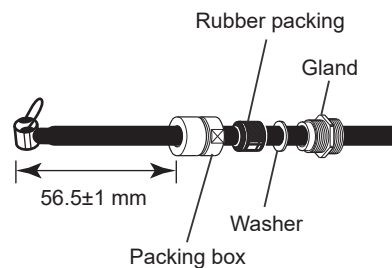

F0524.ai

- (5) Insert the RTD cable and firmly plug its connector into the connecting port in the transmitter's terminal box.
- (6) Screw the union cover to the adaptor body which has fixed to the RTD electrical connection at procedure (2). Screw the union cover at least 6 full turns, and tighten the rock nut.
- (7) If the conduit piping is necessary, screw the conduit to the union coupling after passing the RTD cable through the conduit.
- (8) Finally, confirm whether the connector is plugged surely.

CAUTION

After the cable is plugged as explained above, do not pull the cable or subject it to excessive mechanical shock.
Finally, please remember to confirm whether the connector is plugged surely.

5.4.2 Connecting Shielded Cable for Conduit Use (External temperature input code: -B, -C, and -D)

- RTD connection components: EJX multivariable transmitter and RTD cable

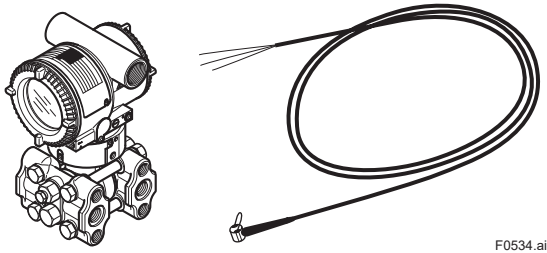

Procedure

- (1) Remove the protection cap protecting the RTD electrical connection and insert the RTD cable.

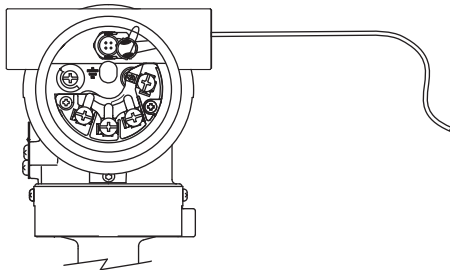

- (2) Remove the cap protecting the connecting port. Then insert the RTD cable and firmly plug the connector into the connecting port in the transmitter's terminal box.
- (3) Insert the cable through the conduit and attach it to the RTD electrical connection.

 **CAUTION**

Do not pull the cable or subject it to excessive mechanical shock.

5.4.3 Removing Shielded Cable with Cable Gland (External temperature input code: -1, -2, -3, and -4)

- (1) By pulling out the string attached to the connector, carefully unplug the connector from the transmitter's connecting port.
- (2) In the case of using 1/2NPT Type or M20 Type cable gland, remove the running coupler and backnut assembly by turning the running coupler. In the case of using G1/2 Type cable gland, loosen the lock nut screwed into the union cover and remove the union cover. RTD cable can be pulled out together with the packing box. Loosen the clamp nut and the gland if necessary.

- (3) Pull the RTD cable out carefully.
- (4) In the case of 1/2NPT Type or M20 Type cable gland, remove the entry from the RTD electrical connection by turning the entry before (3). In the case of G1/2 Type cable gland, loosen the lock nut screwed into the adapter body and remove the adapter body.

 **NOTE**

In the case of G1/2 Type cable gland, remove the rubber packing, washer, gland, clamp ring, clamp nut, union coupling and union cover from the opposite side of RTD connector in order to take out the cable gland from the RTD cable.

5.4.4 Removing Shielded Cable for Conduit Use (External temperature input code: -B, -C, -D)

- (1) By pulling out the string attached to the connector, slowly unplug the connector from the transmitter's connecting port.
- (2) Remove the conduit from the RTD electrical connection.
- (3) Pull the RTD cable out through the RTD electrical connection.

5.4.5 Cable Connection RTD Terminal Box Side

EJX multivariable transmitter RTD I/F is for 3-wire Type RTD, Pt100.

Heed the following when wiring an RTD of the 2- or 4-wire type.

 **NOTE**

Please note that a temperature error will occur when you use a 2-wire RTD because of wiring resistance. Please do not ground the shield on the RTD side of the cable.

 **CAUTION**

Please use only the cables provided with this instrument. When wiring, be sure not to damage the cable's insulation or its core. All the cable cores must have sufficient insulation around them. Do not let the signal line contact the shield line. Do not allow the shield line or the signal line to come the earth potential voltage.

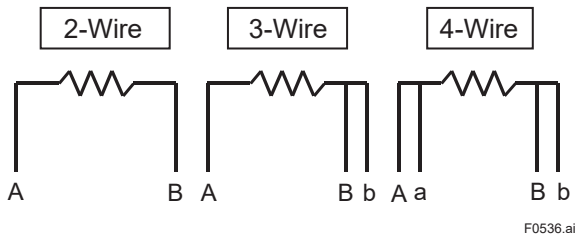

Figure 5.18 The Method of Wiring for the RTD Side

Table 5.2 The Method of Wiring for the RTD Side
RTD Terminal

RTD Terminal	A	a	B	b
2-Wire	White	-	Blue1 and Blue2	-
3-Wire	White	-	Blue1	Blue2
4-Wire	White	open	Blue1	Blue2



NOTE

The color display in the table shows the white line of the cable.
 The cable color could change depending on the cable type.
 Blue1 and blue2 allow changing places.
 For 2-wire Type, connect either which is blue1 or blue2, and give other side as OPEN.

5.6 Power Supply Voltage and Load Resistance

For 4 to 20 mA output only.
 When configuring the loop, make sure that the external load resistance is within the range in the figure below.

(Note) In case of an intrinsically safe transmitter, external load resistance includes safety barrier resistance.

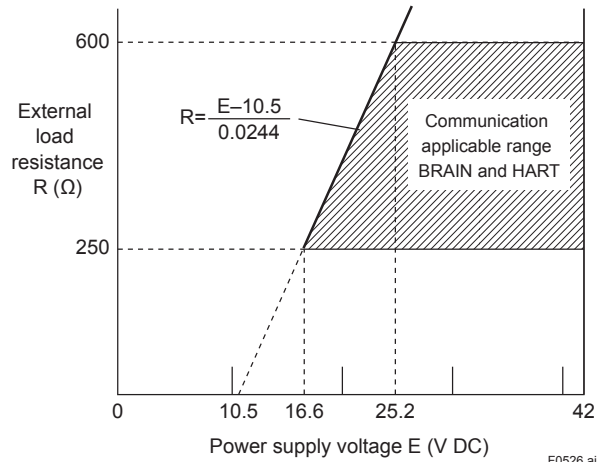

Figure 5.20 Relationship between Power Supply Voltage and External Load Resistance

5.5 Grounding

Grounding is always required for the proper operation of transmitters. Follow the domestic electrical requirements as regulated in each country. For a transmitter with a built-in lightning protector, grounding should satisfy ground resistance of 10Ω or less.

Ground terminals are located on the inside and outside of the terminal box. Either of these terminals may be used.

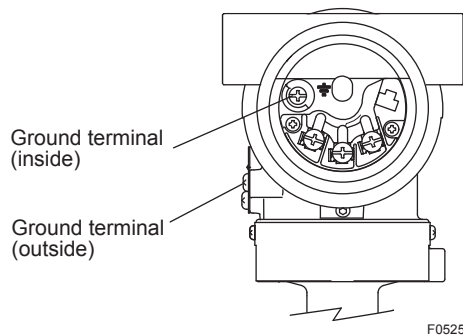

Figure 5.19 Ground Terminals

6. Operation

 **NOTE**

For FOUNDATION Fieldbus, PROFIBUS PA and Modbus communication types and for the transmitter operating confirmation and zeroing by any communication method, refer to each communication manual.

6.1 Preparation for Starting Operation

■ Confirming that Transmitter is Operating Properly

On the integral indicator

- If the wiring system is faulty, the display stays blank.
- If the transmitter is faulty, an error code is displayed.



Self-diagnostic error on the integral indicator (Faulty transmitter)

F0601.ai

■ Verify and Change Transmitter Parameter Setting and Values

The parameters related to the following items are set at factory as specified in order.

- Calibration range
- Integral indicator display
- Output mode
- Software damping (optional)

Other parameters like following are shipped with the default setting.

- Low-cut
- Process alarm setting
- Static pressure range
- Signal characterizer
- Write protection

To confirm or change the values, please refer to each communication manual.

■ Output Status Setting at CPU Failure and Hardware Write Protection

Set the switches as shown in the figure below to set the burn-out direction and write protection. The Burnout switch is set to the H side for delivery (unless option code /C1 or /C2 is specified in the order), and the hardware write protection switch is set to E side except EJX910A

and EJX930A. The setting of the switches can be confirmed via communication.

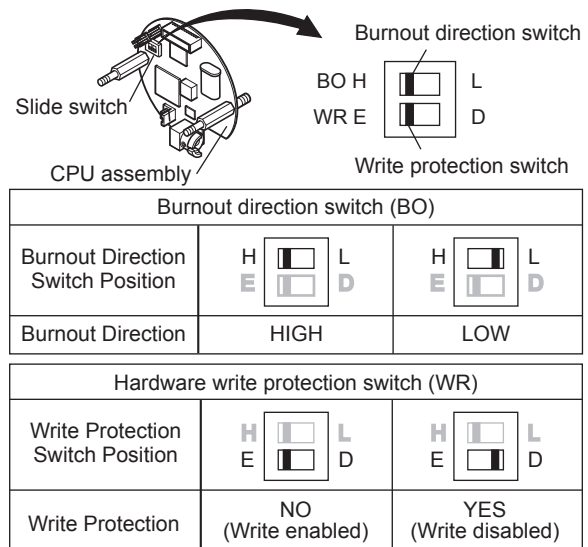

F0602.ai

Figure 6.1 Burn-out Direction and Hardware Write Protection Slide Switch

6.2 Zero Point Adjustment

After completing preparations for operating the transmitter, adjust the zero point.

Zero point adjustment can be done by turning the transmitter's zero-adjustment screw or by using the communicator. This section describes the procedure for the zero-adjustment screw. For the zero-adjustment via communication, procedure, please refer to each communication manual.

 **IMPORTANT**

- Do not turn off the power to the transmitter immediately after performing a zero point adjustment. Powering off within 30 seconds of performing this procedure will return the zero point to its previous setting.
- Using zero-point screw requires the parameter EXT_ZERO_ADJUSTMENT is set to "Enabled." When option code /CJ or /CK is specified, the parameter is set to disabled upon shipment. Refer to each communication manual for confirming or changing the setting.

6.2.1 Adjusting Zero Point for Differential Pressure Transmitters

Before adjusting zero point, make sure that the equalizing valve is open.

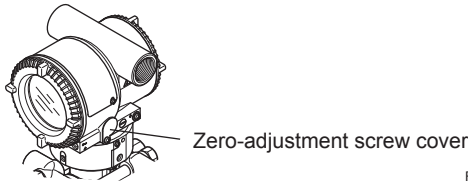

Figure 6.2 External Zero Adjustment Screw

The zero-adjustment screw is located inside the cover. Use a slotted screwdriver to turn the zero-adjustment screw. Equalize the transmitter, then turn the screw clockwise to increase the output or counterclockwise to decrease the output. The zero point adjustment can be made with a resolution of 0.01% of the setting range. The degree of zero adjustments varies with the screw turning speed; turn the screw slowly to make a fine adjustment, quickly to make a rough adjustment.

When using differential pressure transmitters for level measurement and if you cannot obtain the lower range value from the actual measurement value of 0%, refer to subsection 6.2.2(2).

6.2.2 Adjusting Zero Point for Gauge/Absolute Pressure Transmitters

(1) When you can obtain the Low Range Value from the actual measured value of 0% (0 kPa, atmospheric pressure);

For pressure measurement using gauge pressure transmitters, follow the steps below before performing zero point adjustment.

- 1) Close the tap valve (main valve).
- 2) Loosen the fill plug so that the pressure applied to the transmitter is only the head of the seal liquid.
- 3) Adjust the zero point at this status.
- 4) After the adjustment, close the fill plug and then gradually open the tap valve.

Use a slotted screwdriver to turn the zero-adjustment screw. Turn the screw clockwise to increase the output or counterclockwise to decrease the output. The zero point adjustment can be made with a resolution of 0.01% of the setting range. Since the degree of the zero adjustment varies with the screw turning speed, turn the screw slowly to make a fine adjustment and quickly to make a rough adjustment.

(2) When you cannot obtain the Low Range Value from the actual measured value of 0%;

Adjust the transmitter output to the actual measured value obtained by a digital manometer or a glass gauge.

[Example]

The measuring range of 50 to 250 kPa; the actual measured value of 130 kPa.

$$\text{Actual measured value} = \frac{130 - 50}{250 - 50} \times 100 = 40.0\% \quad (=10.4\text{mA})$$

Turn the screw to match the output signal to the actual measured value.

6.3 Local Parameter Setting



WARNING

The local push button on the integral indicator must not be used in a hazardous area. When it is necessary to use the push button, operate it in a non-hazardous location.



IMPORTANT

- Do not turn off the power to the transmitter immediately after performing parameter setting. Powering off within 30 seconds of performing this procedure will return the parameter to its previous setting.
- The parameter of Ext SW must be "Enabled" to perform this configuration. See the user's manual IM 01C25T (HART/BRAIN) for the setting procedure. When option code /CJ or /CK is specified, this parameter is set to disabled upon shipment.
- The Local Parameter Setting function is available with HART or BRAIN communication type.

6.3.1 Local Parameter Setting (LPS) Overview

Parameter configuration by the external adjustment screw and push button (integral indicator code E) offers easy and quick setup for parameters of Loop test, Tag number, Unit, LRV, URV, Damping, Output mode (linear/square root), Display out 1, and Re-range by applying actual pressure (LRV/URV) and Device Information. There is no effect on measurement signal (analog output or communication signal) when Local Parameter Setting is carried out.

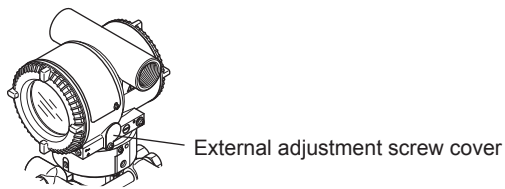

Figure 6.3 External Adjustment Screw

F0604.ai

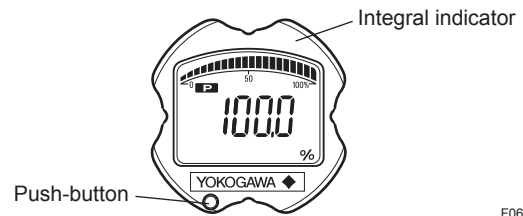
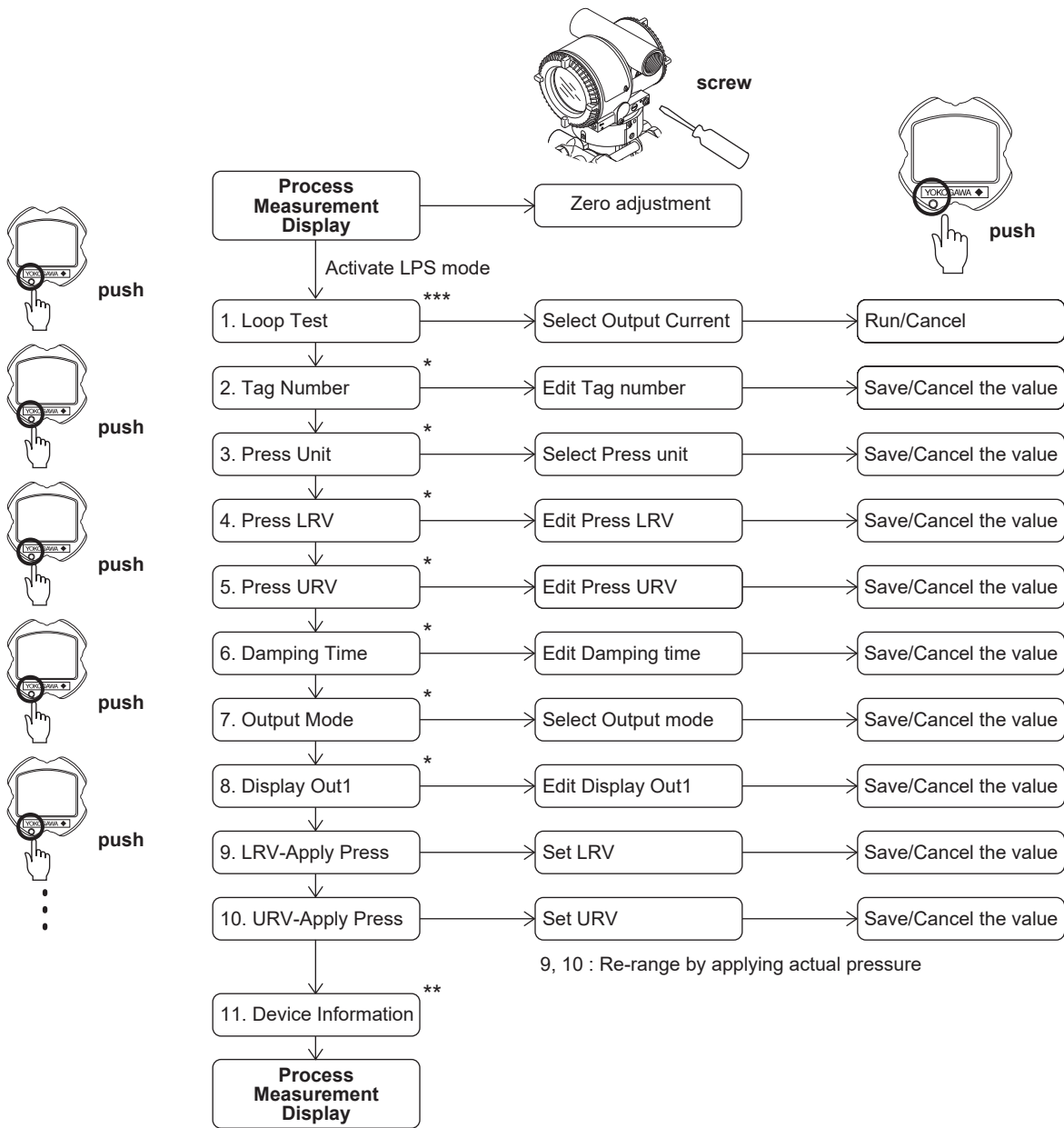

Figure 6.4 Range-Setting Switch (push button)

F0605.ai



F0606.ai

*: These parameter configurations are available with the software revision (SOFT REV)2.03 or later. Software revision can be checked via a field communicator (HART/BRAIN) or DTM. Please refer to IM 01C25T01 for HART parameter "Software rev" and IM 01C25T03 for BRAIN "SOFT REV."
 **: This parameter configuration is available with the software revision (SOFT REV) 3.01 or later.
 ***: This parameter configuration is available with the software revision (SOFT REV) 5.01 or later.

7. Errors and Countermeasures



NOTE

For HART protocol revision 7, FOUNDATION Fieldbus, PROFIBUS PA and Modbus communication types, please refer to each communication manual.

The table below shows a summary of error messages for BRAIN and HART (protocol revision 5) protocols.

Table 7.1 Alarm Message Summary (Except EJX910A and EJX930A)

Indicator	Cause	Output Operation during Error	Countermeasure		
None					
AL. 01 CAP. ERR	Sensor problem.	Outputs the signal (Hold, High, or Low) set with parameter.	Replace capsule when error keeps appearing even after restart.		
	Capsule temperature sensor problem.				
	Capsule EEPROM problem.				
AL. 02 AMP. ERR	Amplifier temperature sensor problem.	Outputs the signal (Hold, High, or Low) set with parameter.	Replace amplifier.		
	Amplifier EEPROM problem.				
	Amplifier problem.				
AL. 10 PRESS	Input is outside measurement range limit of capsule.	Outputs high range limit value or low range limit value.	Check input or replace capsule when necessary.		
AL. 11 ST. PRSS	Static pressure exceeds limit.	Continues to operate and output.			
AL. 12 CAP. TMP	Capsule temperature is outside range (-50 to 130°C).			Use heat insulation or make lagging to keep temperature within range.	
AL. 13 AMP. TMP	Amplifier temperature is outside range (-50 to 95°C).				
AL. 30 RANGE	Output is outside upper or lower range limit value.	Outputs high range limit value or low range limit value.	Check input and range setting, and change them as needed.		
AL. 31 SP. RNG	Static pressure exceeds specified range.	Continues to operate and output.			
AL. 35*1 P. HI	Input pressure exceeds specified threshold.	Holds output immediately before error occurred.	Check input.		
AL. 36*1 P. LO					
AL. 37*1 SP. HI	Input static pressure exceeds specified threshold.				
AL. 38*1 SP. LO					
AL. 39*1 TMP. HI	Detected temperature exceeds specified threshold.				
AL. 40*1 TMP. LO					
AL. 50 P. LRV	Specified value is outside of setting range.				Check setting and change them as needed.
AL. 51 P. URV					
AL. 52 P. SPN					
AL. 53 P. ADJ				Continues to operate and output.	
AL. 54 SP. RNG		Continues to operate and output holding static pressure in %.	Check setting and change them as needed.		
AL. 55 SP. ADJ		Continues to operate and output.	Check input.		
AL. 60 SC. CFG		Specified values or settings to define signal characterizer function do not satisfy the condition.		Check setting and change them as needed.	
AL. 79 OV. DISP	Displayed value exceeds limit.				

*1: These alarms may appear only when process alarm function is activated.

Table 7.2 Alarm Message Summary (For EJX910A and EJX930A, HART protocol type)

Integral indicator	Cause	4-20mA Output operation during error	Countermeasure
AL. 01 CAP.ERR	Sensor problem.	Outputs the signal (High or Low) set with burnout direction switch. [status output: undefined]	Replace capsule if the error recurs after the transmitter is restarted.
	Capsule temperature sensor problem.		Replace capsule.
	Capsule EEPROM problem.		
AL. 02 AMP.ERR	Amplifier temperature sensor problem.		Replace amplifier.
	Amplifier EEPROM problem.		
	Amplifier problem.		
	A/D Converter problem.		
AL. 03 ET.ERR	External temperature sensor disconnection.		Check external temperature sensor.
—	No device ID is found.	Continues to operate and output.	Replace amplifier.
AL. 10 PRESS	Differential pressure is outside measurement range limit of capsule.	When PV is Pres Output AO upper limit or AO Lower limit.	Check input or replace capsule when necessary.
AL. 11 ST. PRSS	Static pressure exceeds limit.	When PV is SP Output AO upper limit or AO Lower limit.	
AL. 12 CAP.TMP	Capsule temperature is outside range (–50 to 130°C).	Continues to operate and output.	Use heat insulation or make lagging to keep temperature within range.
AL. 13 AMP.TMP	Amplifier temperature is outside range (–50 to 95°C).		
AL. 14 EXT. TMP	External temperature is outside range.	When PV is ET Output AO upper limit or AO Lower limit.	
AL. 15 EXT. TMP	External temperature sensor resistance is out specification.		
AL. 16 PLS	Pulse output is out specification.	Continues to operate and output.	Check settings and change them.
AL. 30 PRS.RNG	Differential pressure exceeds specified range.	When PV is Pres. Output AO upper limit or lower limit.	Check input and range setting, and change them as needed.
AL. 31 SP. RNG	Static pressure exceeds specified range.	When PV is SP Output AO upper limit or lower limit.	
AL. 32 F. RNG	Flow exceeds specified range.	When PV is Flow Output AO upper limit or lower limit.	
AL. 33 ET. RNG	External temperature exceeds specified range.	When PV is ET Output AO upper limit or lower limit.	
AL. 35 P.HI	Input pressure exceeds specified threshold.	Continues to operate and output.	Check input.
AL. 36 P.LO			
AL. 37 SP.HI	Input static pressure exceeds specified threshold.		
AL. 38 SP.LO			
AL. 41 F.HI	Input flow exceeds specified threshold.		
AL. 42 F.LO			
AL. 43 ET.HI	Input external temperature exceeds specified threshold.		
AL. 44 ET.LO			
AL. 50 P. LRV	Specified value is outside of setting range.	Holds at the output value that existed immediately before the error occurred.	Check settings and change them as needed.
AL. 51 P. URV		Continues to operate and output.	Adjust settings and change them as needed.
AL. 52 P. SPN			
AL. 53 P. ADJ		Holds at the output value that existed immediately before the error occurred.	Check settings and change them as needed.
AL. 54 SP. RNG			
AL. 55 SP. ADJ			
AL. 56 ET. RNG		Holds at the output value that existed immediately before the error occurred.	Check settings and change them as needed.
AL. 57 ET. ADJ			
AL. 58 FL. ADJ		Holds at the output value that existed immediately before the error occurred.	Check settings and change them as needed.
AL. 59 PLS.ADJ	Specified value is outside of setting pulse output.	Normal calculation.	
—	Under Temperature Fix Mode. PV is ET	Temp. Output Fix at 4mA.	Leave from Temperature Fix Mode.

Integral indicator	Cause	4-20mA Output operation during error	Countermeasure
AL. 79 OV. DISP	Displayed value exceeds limit.	Continues to operate and output.	Check settings and change them as needed.
AL.87 FLG. HI	Flange temperature exceeds a preset upper limit.	It depends on the Diag Out Option setting. Off: Continue to operate and output. Burnout:Outputs AO upper limit or AO lower limit. Fall back:Outputs Diag Out Fixed Val.	Check the heater failure. Check the capsule temp. and Amplifier temp. Adjust Flg Temp Coef.
AL. 87 FLG. LO	Flange temperature is below a preset lower limit.		
AL.88 INVR.DP	Differential pressure/pressure fluctuation does not reach the reference level required to blockage detection so that no blockage detection is carried out.	Continue to operate and output.	Check process condition.
AL.88 INVR.SL	Low-pressure-side fluctuation does not reach the reference fluctuation level required to blockage detection.		
AL.88 INVR.SH	High-pressure-side fluctuation does not reach the reference fluctuation level required to blockage detection.		
AL.88 INVR.F	BlkF can not be used for blockage detection for some reasons.		
AL.89 ILBD.OV	Appointed the diagnosis range outside.		
AL.89 B BLK	B Blocking (both-side blockage) is detected.		
AL.89 H BLK	High-pressure-side blockage is detected.		
AL.89 L BLK	Low-pressure-side blockage is detected.		
AL.89 H LRG	Pressure fluctuation amplitude of high-pressure side is large.		
AL.89 L LRG	Pressure fluctuation amplitude of low-pressure side is large.		
AL.89 A BLK	A Blocking (single-side blockage) is detected.		
AL. 90 SIM	Under Simulation Mode for flow.	Simulate input output.	Check Simulation Mode.
AL. 91 F. SIM	Under Simulation Mode for device variables.	Output the setting value of Simulate-Value.	Check Simulation Mode.
AL. 91 P. SIM			
AL.91 SP. SIM			
AL. 91 ET. SIM			
AL. 91 TF. SIM			
AL. 91 PCT. SIM			
AL. 91 AO. SIM			

Revision Information

- Title : EJX and EJA-E Series
Differential Pressure and Pressure Transmitters Installation Manual
- Manual No. : IM 01C25A01-01E

Edition	Date	Page	Revised Item
1st	Aug. 2009		New publication
2nd	Apr. 2010	7 to 14	2.4 Add limitation of ambient temperature for/HE.
3rd	Oct. 2010	1, 5 and 15 1 2 3 30 to 31 41 to 43	Add EJX610A and EJX630A. 1. Add HART 7 manual. 1. Add note for wet location in (c). 3. Add EJX630A. 5.4 Modify pictures of cable gland. 8. Add parameters for EJX900A (Dev.rev.2).
4th	Aug. 2011	1 14 27 28 36 37 40	1. Modify Table 1.1. 2.4.3 Alter the note (*1) for name plate. 5.2.2 Change the picture of configuration tool. 5.2.4 Add note (*3). 7 Add HART protocol revision 7 to NOTE. 7 Modify Table 7.2. 8 Add HART protocol revision 7 and EJX910A/EJX930A to NOTE. Delete the Menu Tree for EJX910A/EJX930A.
5th	Mar. 2012		Revise CD-R (Ed5).
6th	Aug.2012	— 1 10 to 15 17 42-46	Add EJA-E series. Add table for EJA to Table 1.1. Add note for representation of model name. Revise ATEX approval. Add models to PED table. Add parameters and notes.
7th	Jun. 2013	— 7 13 to 14 16 and 17 20	Add PROFIBUS PA. Add note for multiple approval option. Replace ATEX type n by ATEX Ex ic. Add EJA110E with /HG to PED table. Modify note for installation height.
8th	June 2014	2 8 17 28 to 34 28 37 to 42	1. Add note for symbols. 2.4.2 Revise category for CSA Nonincendive. 2.7 Update safety requirement standard. 5. Revise drawings and symbols for terminal. 5.2.1 Add note for power supply. 6.3 Add local parameter setting function.
9th	Oct. 2014	8 10 13 16 to 17 17 29 30 33 36 40 41 42	2.4.1 Add information for 1 to 5 V output. 2.4.2 Add information for 1 to 5 V output. 2.4.3 Add information for 1 to 5 V output. 2.4.5 Add EPL code. Revise applicable standard. Add information for 1 to 5 V output. Add note for electro static charge. Add electrical connection. 2.5 Add standard for PROFIBUS. 5.2 Add Figure 5.2 Terminal. 5.2.1 Add information for 1 to 5 V output. 5.3.1 Add information for 1 to 5 V output. 5.6 Add applicability. 6.3.1 Add "10.Device information" 6.3.3 Add note in the figure. Add method of cancel/save. Delete 6.3.4 to 6.3.11 7. Correct AL31 output operation.
10th	Apr. 2015	1 2 3	Removal of CD-R. 1. Modify descriptions. Replace CD-ROM information by the downloading information. Modify structure of Table 1.1. Delete note about CD-ROM. 1.1 Add WARNING sign. Add (g) and (h).

Edition	Date	Page	Revised Item
10th	Apr. 2015	5 6 7 to 28 28 30 41, 49, 52 51	2. Modify Table 2.1. 2.1 Replace Figure 2.2. 2.4 Delete Note for CD-ROM. Add Fieldbus intrinsically safe type. (2.4.1 b and c, 2.4.2 b, 2.4.3 c, d and g, and 2.4.4 b.) 2.5 for Profibus → for Fieldbus 2.7 Add C22.2 standard. 5, 6 and 7 Modify note for CD-ROM. Delete 6.3.2.
11th	July 2015	26 to 31 26 53	2.4.4 Add SU21 and SS26. Add a, b, c and d. Revise Note 2. 6.3.1 Delete note for 10. from Figure 6.5.
12th	Feb. 2017	1 4 6 8 to 12 16 to 23 16 17 20 23 24 27 28 30	Add IM for Diaphragm Seal System and DRS. Add a note on User's Manual for code Z. Add statement for Chinese ROHS. Update the L-type bracket in Figure 2.1. Delete descriptions and add Control Drawing for FM approval. Update ATEX applicable standards. Revise descriptions for item a. Delete item "b. ATEX Intrinsically Safe for HART Protocol Type for EJX9□0A" Revise notes for ATEX flameproof type. Update the tag plate for ATEX flameproof. Delete tag plate for EJX9□0A intrinsically safe for HART/BRAIN. Update IECEx applicable standards. Revise notes for IECEx intrinsically safe type. Delete items "e. IECEx Intrinsically Safe / type n for HART/BRAIN Protocol Type (Except for EJX9□0A)" and "f. IECEx Intrinsically Safe / type n for Fieldbus Type (Except for EJX9□0A). Update PED information. (97/23/EC → 2014/68/EU) Update the L-type bracket in Figure 3.3.
13th	Oct. 2019	1 8 to 13 11 21 28 28 30 30 31 36, 39 50, 51	1. Add S2 for EJA-E series. 2.4.1 Change the description for FM Intrinsically Safe/Nonincendive for HART/BRAIN Protocol Type. 2.4.1 Change the applicable standard for FM Explosionproof. 2.4.3 Change the descriptions for ATEX Flameproof Type. 2.5 Delete the sentence: (for use in industrial locations) 2.5 Add the caution. 2.7 Add EU RoHS Directive. 2.8 Delete the description for altitude of installation site. 3. Add the caution for installing diaphragm seals, process connectors or manifolds. 4, 4.3.1 Add the caution for installing a process connector. 6.3.1 Add the descriptions for Loop test.
14th	Apr. 2020	— 9 14 15 17 18 19 22 24 26 28 to 30 33	Updates of agency approvals. 2.4.1 b. Update Note 1 & 4. 2.4.2 a. Update Note 1 b. Update Standards and ambient temp. c. Update Standards and distance of seal. (50→45 cm) d. Update Note 2. 2.4.3 b. Update all the descriptions. d. Update Note 1, 3, 4, 5, 6 and 7. f. Update all the descriptions. (6) Update nameplates. 2.4.4 c. & d. Update all the descriptions. 2.8 Recover (4).
15th	July 2021	9 15 18 19 21 23 25 26 32 35	2.4.1 b. Update ambient temp. 2.4.2 b. Update ambient temp. 2.4.3 a. Update all the descriptions. b. Update applicable standard and ambient/process temperature range. c. Update all the descriptions. e. Update ATEX intrinsically safe Ex ic. (2) Delete screw size and marking. Delete WARNING. (3) Update tag plates. 2.4.4 a. Update all the descriptions. c. Update applicable standard and ambient/process temperature range. 2.7 Change EU RoHS Directive. 3.2.1 Add IMPORTANT.

Edition	Date	Page	Revised Item
16th	Jan. 2023	4 6 to 7 8 26 31 33 34 35 36 to 37 42 47 52 52 to 56 57 and 58	1.1 (h) Add description about importer. 2. Add information about bracket code P and option code /BS. 2.4 Add information to CAUTION. Add IMPORTANT information about blind plugs. 2.4.4 Add "SU22". 2.4.4 Add "f. IECEx Flameproof Type." 2.6 Add V range for EJ□130□ and TS(°C) in the PED table. 2.7 Add USA to the production site. 3.1 Add position adjustable bracket to Figure 3.3. 3.1 Add "3.1.1 How to install the position adjustable bracket" 4.1.1 (1) Add information for /BS. 5.1 dust cap → dust cap(plug) 5.3.2 (2) Add IMPORATNT for flameproof type. 5.4 Update the information for wiring RTD. 6.2 and 6.3 Add note for /CJ and /CK in IMPORTANT.
17th	Sep. 2025	14 and 15 27 34 52	2.4.2 Revise Applicable Standard of CSA Intrinsically Safe Type. 2.4.4 Change the descriptions for IECEx Intrinsically Safe Ex ic. 2.7 Add UAE to the condition of the RoHS compliant production site. 5.3.2 Revise information of IMPORTANT for requirement of IEC 60079-14.
18th	Nov. 2025	4	1.1 (i) Change the descriptions.