

# Company Introduction

# 01 | Introduction Company Profile

06 Established  
Robustech Co., Ltd.

**2014**

11 Founded a R&D Center

**2018**

02 Registered as a vendor  
with Hanwha Engine

**2022**

07 Signed Official Agency  
with YOKOGAWA

**2025**

**2017**

02 Registered Venture Business  
09 Signed Official Agency  
with DANFOSS

**2020**

09 Registered as a vendor with  
Hyundai Heavy Industries-Turbo Machinery  
10 Registered as a vendor with  
Samsung Heavy Industries

**2023**

12 Registered as a vendor  
with Hanwha Power Systems

**2026**

03 Signed 1st Official Agency  
with SCANA SKARPENORD  
in South Korea



Sales  
20 Mil USD



Employees  
60



Workshop  
3,577 m<sup>2</sup>



#1 Head Office - Gimhae  
#2 Factory - Busan  
Korea



# 01 | Introduction Organization

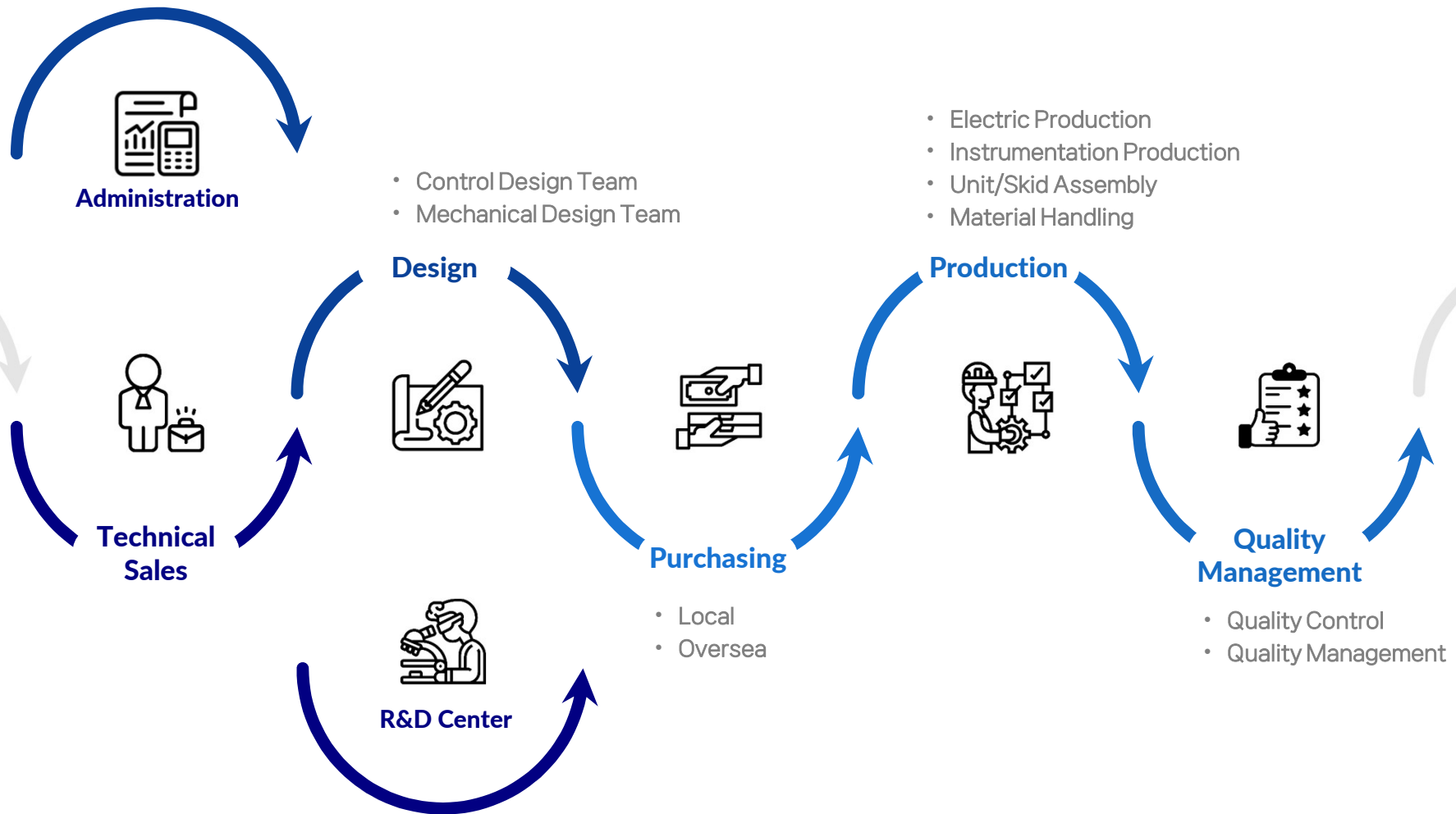

Robustech

# Contents

## 01

### Introduction

- Company Profile
- Management Objectives
- Organization

## 02

### Business Area

- Certificates
- Main Customers & Agents
- Marine Business
- Onshore Business
- Food & Beverage Business
- Global Partnership Members

# 01 | Introduction Management Objectives

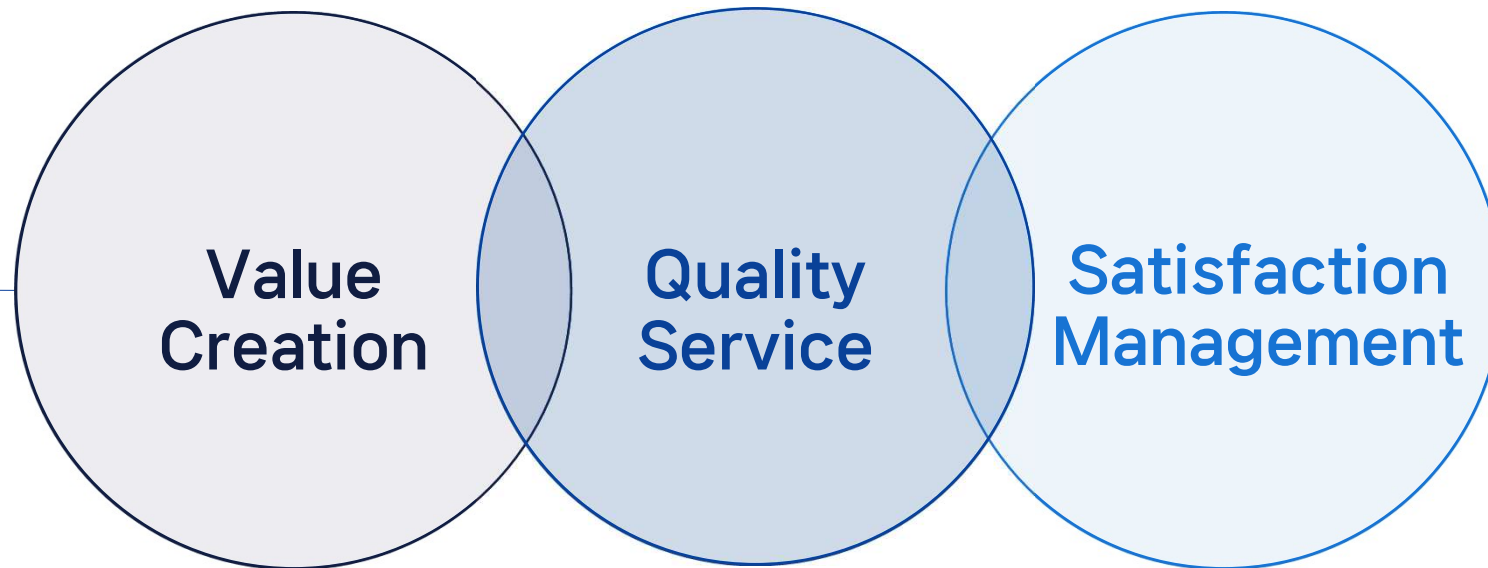

# 01 | Introduction Organization

## Design Division



21 명



### Control

5 P

VFD Starter Group Panel

PLC Control Panel &  
Instrument

Inverter Control Panel

### Mechanical 1

6 P

Water Treatment  
System for EGR

Butter Tank With Supply  
Unit

Ammonia Injector Cooling  
Water System

### Mechanical 2

5 P

DGS Support System

Pressure Gauge Board  
For LNG Carrier

ESDS For Oil & Chemical  
Carrier

### R&D Center

5 P

Defense Industry

Shipbuilding Industry

New Items

# 01 | Introduction Main Customer



# 01 Introduction Certificates



ISO 9001



ISO 14001



ISO 45001



R&D Center Cert.

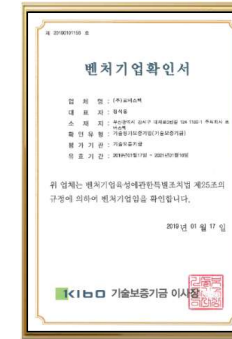

Venture Company Cert.



Inno-Biz



Ace Stella



The Best Small Company Cert.



Technical Evaluation Cert.



Debubblers Patent Cert.

## 02 | Main Business



### Marine Business

- Water Treatment System for EGR
- VFD Starter Group Panel
- For Ballast Water Management System
- Pressure Gauge Board For LNG Carrier
- ESDS For IAS / FGSS
- PLC Control Panel & Instrument
- ESDS For Oil & Chemical Carrier



### Plant Business

- DGS Support System & Wiring Work
- Tubing Work
- Inverter Control Panel for APR-1400



### Food & Beverage Business

- Centrifuge separator Unit





PRODUCTS

- Actuators
- Solenoid valve cabinet
- Hydraulic Power Units
- Computerized valve control
- Valve remote control system**
- Downloads
- Hydraulic Control Cabinet
- Sales conditions
- Campaign OMRON



Solenoid Valve Cabinet:

- 10 units with PLC located in SVC
- The PLC allows 576 common alarm by contact for connection to ships DCS
- The logic controller in the SVC runs independently from the control room computer and has a dedicated operator panel mounted in cabinet door
- The control system will still run from the operator panel, even if the control computer is disabled
- The operator panel utilizes a powerful tool for maintenance work and as backup control station

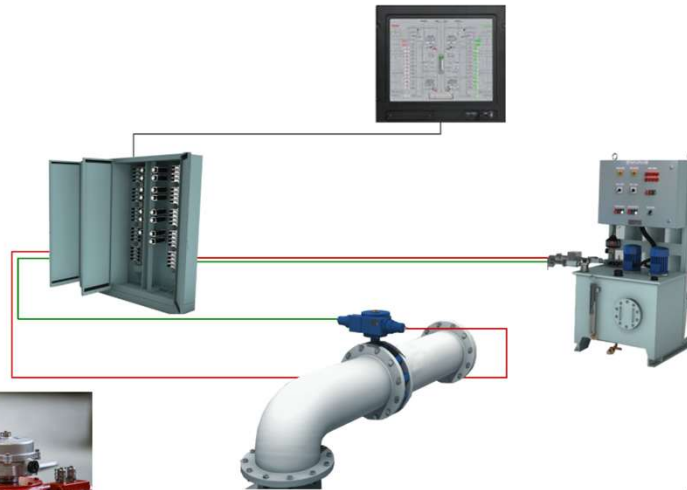

## VRCS (Scana Skarpenord)

A Valve Remote Control System (VRCS) is an automated solution that allows operators to open, close, and monitor multiple valves from a central control station, typically used in ships and offshore plants. It improves safety, efficiency, and reliability by replacing manual valve operation with hydraulic, pneumatic, or electro-hydraulic actuation.



### System Engineering

- Basic Design
- Detailed Design(3D Modeling)
- Drawing Approval



### Module Manufacturing

- Procurement
- Production
- Shop Test

# 02 | Main Business Marine

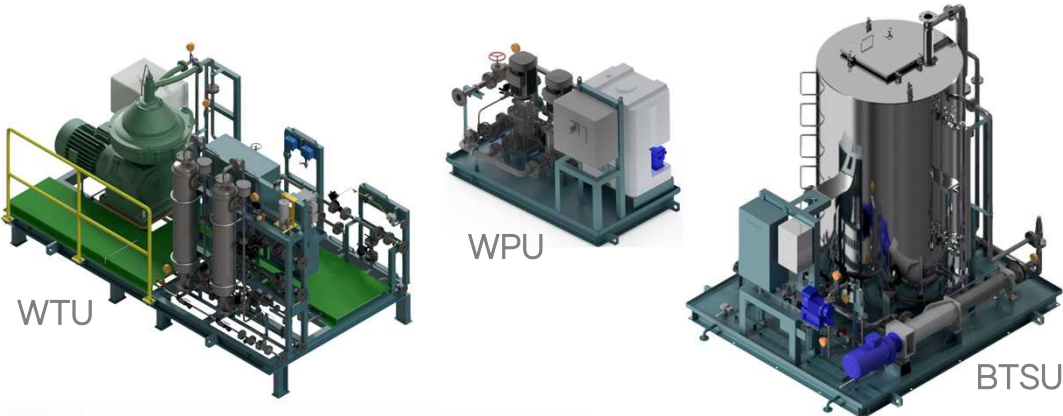

## Water Treatment System for EGR

Exhaust Gas Recirculation is one of the solutions to reduce Nitrogen Oxides in marine engine exhaust gases. Recirculated exhaust gases shall be cleaned to prevent sulfur or particles in the exhaust gases from damaging the engine. Water Treatment System is essential to maintain water to clean, cool, and neutralize exhaust gases.

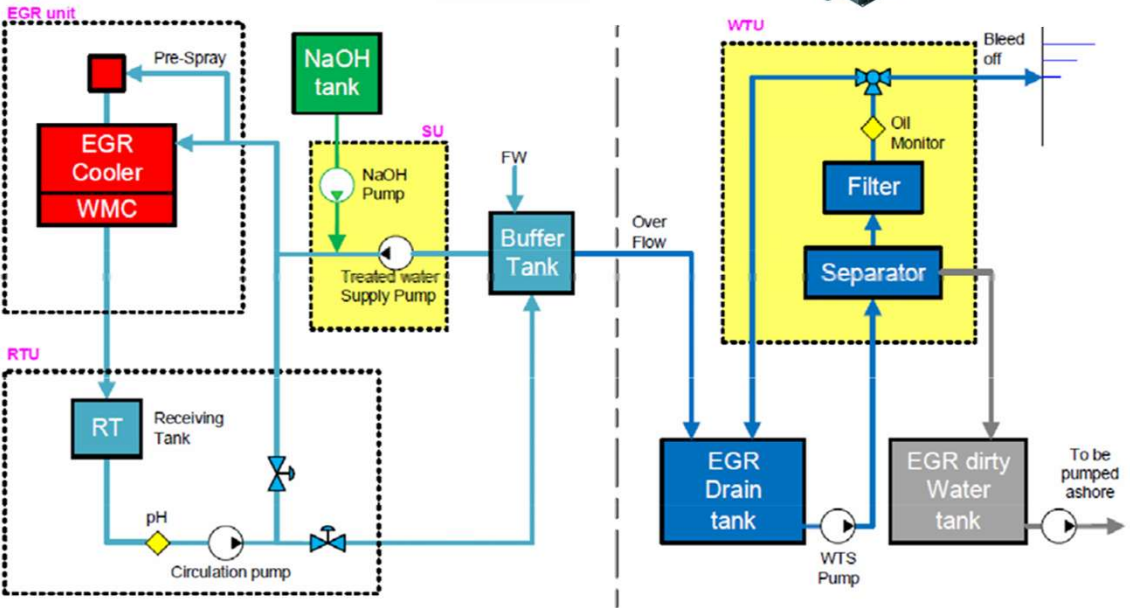

### System Engineering

- Basic Design
- Detailed Design(3D Modeling)
- Drawing Approval



### Module Manufacturing

- Procurement
- Production
- Shop Test

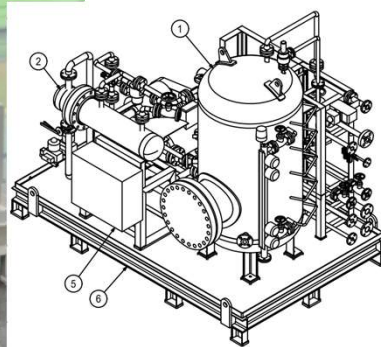

# Ammonia Injector Water Cooling System For Ammonia Engine

The system supplies cooling water to the fuel injection nozzles of an ammonia-fueled marine engine



## System Engineering

- Basic Design
- Detailed Design(3D Modeling)
- Drawing Approval



## Module Manufacturing

- Procurement
- Production
- Shop Test

03. 2025 Delivered Test Facility (Yard : HHI-EMD)

06. 2025 Delivered 1<sup>st</sup> Commercial System (Yard : HMD)



## VFD Starter Group Panel For LNG Booster Pump

LNG Booster Pump is an essential equipment for boosting LNG at a cryogenic temperature of  $-163\text{ }^{\circ}\text{C}$  to the engine or bunkering LNG carried by an LNG ship to land.

VFD Starter Group Panel is a system controlled by LNG Booster Pump PLC and Inverter.



**System Engineering**

**Module Manufacturing**

### LNG Cargo Pump-line

- Main Cargo Pump
- Spray Stripping Pump
- Fuel Gas Pump
- Emergency Pump

### LNG Supply Pump

### LPG / LCO<sub>2</sub> Cargo Pump-line



02 | Main Business Marine



# Units for Ballast Water Management System

BWMS is the equipment that blocks the inflow of exotic species from other areas by sterilizing aquatic and micro organisms contained in ballast water discharged from ships. Since 2009, BWT has been mandatory for new ships built after 2012 and for all ships operating after 2017.

- Auto Neutralization Unit
- TRO Sensor Unit
- Conductivity Sensor Unit
- Fresh water Temperature Sensor
- AFU Control Panel for Electro Chamber Unit

Cooling Pipe  
PS / PI, TS / TI  
EPJ / ESJ

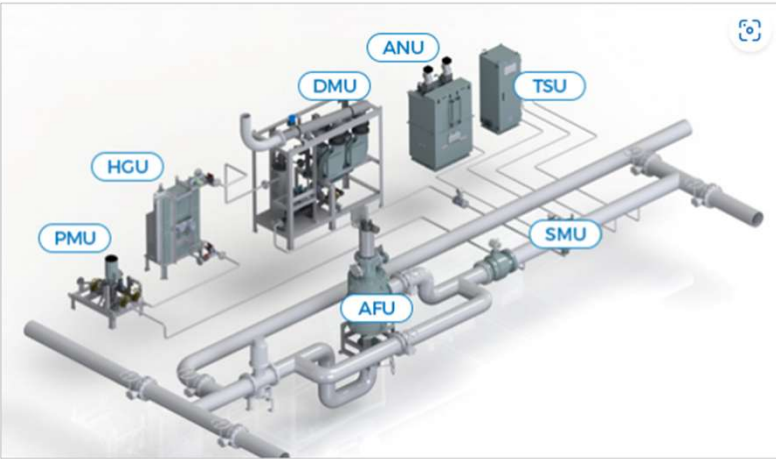



## Pressure Gauge Board For LNG Carrier

PGB is equipment for real-time monitoring of the status of various tanks and lines of LNG carriers.



### System Engineering

- Basic Design
- Detailed Design(3D Modeling)
- Drawing Approval



### Module Manufacturing

- Procurement
- Production
- Shop Test

## 02 | Main Business Plant

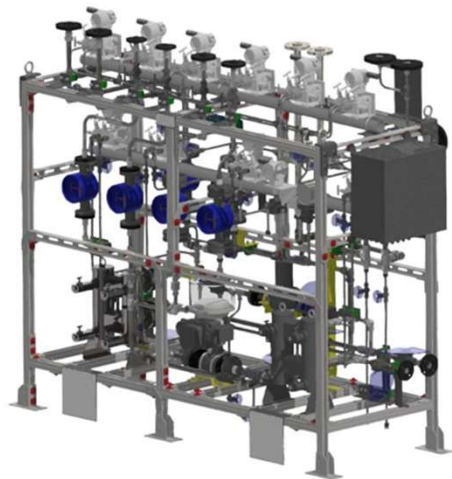

Dry Gas Seal Support System  
Unit Control Panel  
Junction Box & Wiring work  
Gauge Board & Tubing work

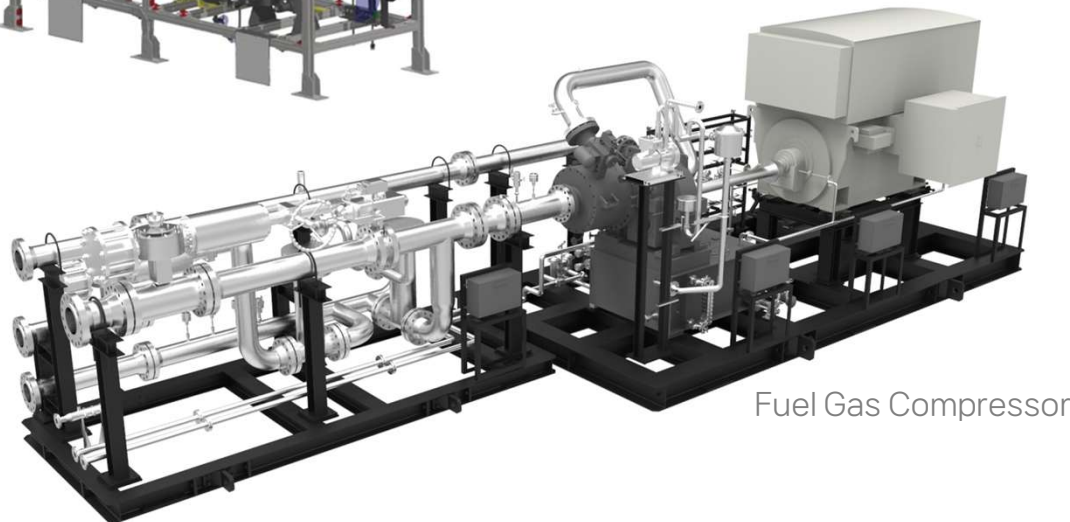

Fuel Gas Compressor

## Dry Gas Seal Support System for FGC

Fuel Gas Compressor is a high-efficiency core power generation solution used to supply gas fuel to gas turbines. Dry Gas Seal Support System stably supplies seal gas according to the required flow rate (pressure) to prevent leakage of Lube Oil which is supplied to compressor process gas or bearings.



### System Engineering

- Basic Design
- Detailed Design (3D Modeling)
- Drawing Approval



### Module Manufacturing

- Purchase Procurement
- Production
- Shop Test



## GT Water Washing Skid

Designed for precision removal of dust, salt, and oil deposits, our Water Washing Skid restores compressor blade integrity. It is an essential solution to prevent efficiency loss, maximize heat rate, and ensure peak power generation performance.



### System Engineering

- Basic Design
- Detailed Design(3D Modeling)
- Drawing Approval



### Module Manufacturing

- Purchase Procurement
- Production
- Shop Test

# 02 | Main Business Plant



## MBR Water Treatment System

The MBR Water Treatment System is a containerized wastewater treatment solution utilizing advanced MBR (Membrane Bioreactor) technology for sewage treatment. By combining biological treatment with high-performance membrane filtration, it delivers superior effluent quality within a compact footprint.

The modular container design enables rapid deployment, stable operation, and reliable compliance with environmental discharge regulations.



### System Engineering

- Basic Design
- Detailed Design(3D Modeling)
- Drawing Approval



### Module Manufacturing

- Purchase Procurement
- Production
- Shop Test

## 02 | Main Business Plant



### Land-based Recirculating Aquaculture System



## Land-based Recirculating Aquaculture System

A Land-based Recirculating Aquaculture System (RAS) is an advanced, sustainable fish farming method that operates indoors, continuously filtering and reusing water to maintain optimal conditions for fish growth while minimizing environmental impact. It recycles 90–95% of water, making it highly efficient compared to traditional aquaculture.



### System Engineering

- Basic Design
- Detailed Design
- Drawing Approval



### Module Manufacturing

- Purchase Procurement
- Production
- Shop Test
- Wiring Work

## 03 | R&D System & Solution

Physical AI based on Multipurposed AI Terminal Management solution – On device AI based on 'SMP: Smart Maritime Port' System

# 'Smart Maritime Port Management'



- Cargo / stowage monitoring
- Vessel monitoring
- Ship towing & escort operations
- Electric-propulsion smart barges
- Drone taxi take-off / landing port
- Harbor / port-wide monitoring

This slide frames SMP as an integrated operating picture: surveillance and analytics across cargo, vessels, and port infrastructure, plus electric harbor craft and aerial mobility nodes. Keep emphasis on integration (one terminal, many digital and physical layers), not on committing to a single vendor stack prematurely.

## 03 | R&D System & Solution

Physical AI based on Multipurposed AI Terminal Management solution – Physical AI based on 'Port-Bot' System

### 'Port-Bot'



Describe a small smart harbor craft for close-quarters tasks: line handling support, equipment shuttle, environmental sensors, or escort in confined basins. Emphasize electric/hybrid readiness, sensor fusion, and command from the GIS-based control platform

## 03 | R&D System & Solution

Physical AI based on Multipurposed AI Terminal Management solution – Physical AI based on 'Air-Bot' System

### 'AI Port Air-Bot'



Explain the role of an autonomous or semi-autonomous aerial system for perimeter patrol, berth approach monitoring, thermal/visual inspection, and situational awareness feeding the port control system. Tie to safety, emissions monitoring support, and faster incident detection.

## 03 | R&D System & Solution

Physical AI based on Multipurposed AI Terminal Management solution – AI Imaging Analysis based on ‘Smart Cargo Estimate’ System

# ‘AI Image Analysis Solution’

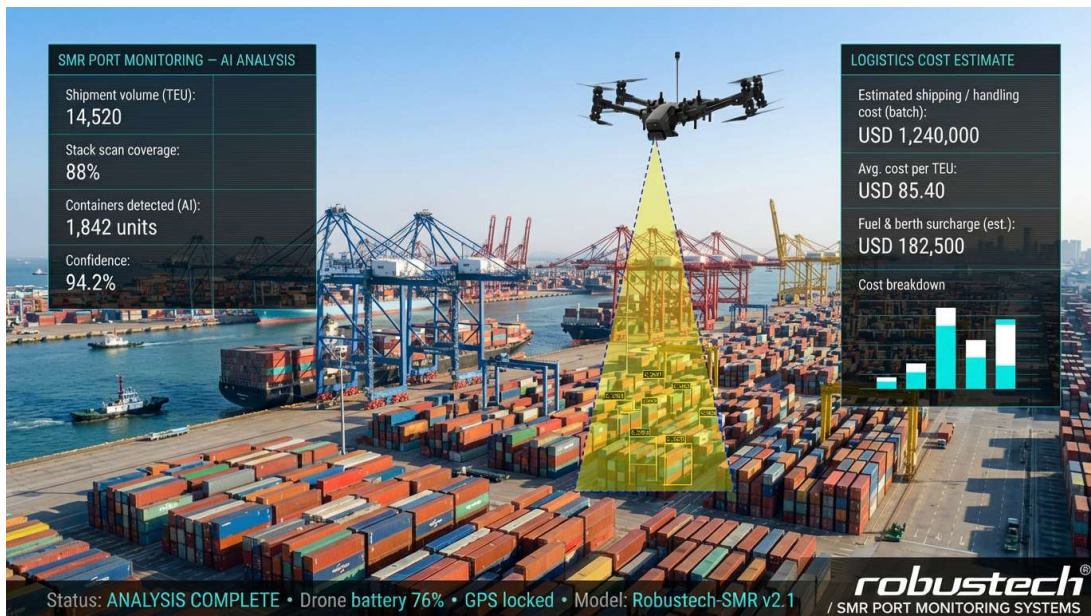

This screen summarizes automated detection of container stacks and estimated shipment volume and logistics cost from the current scan area.

- Real-time stack coverage and container detection with confidence scoring
- Shipment volume (TEU) derived from the scanned yard segment
- Estimated shipping / handling cost and average cost per TEU
- Operational context: drone status, GPS lock, and analysis model ID

# 03 | R&D System & Solution

Physical AI based on Multipurposed AI Terminal Management solution – GIS Based on ‘Smart Harbor Management’ Solution

## ‘GIS-based AI Image Analysis Solution’



This is the digital twin / geospatial command layer: fuse AIS, berth schedules, terminal TMS/PCS data, and video or drone feeds. AI assists with classification, alerting, and answers in natural language, while humans retain authority for safety-critical decisions.

# 02 | Main Business R&D center



## R&D items

Driving innovation in the defense, aerospace, and drone sectors, we specialize in engineering customized, one-of-a-kind equipment and integrated systems tailored to meet the most demanding technical requirements



### System Engineering

- Basic Design
- Detailed Design
- Drawing Approval



### Module Manufacturing

- Purchase Procurement
- Production
- Shop Test
- Wiring Work

# 02 Main Business Food & Beverage (Centrifuge Separator Unit)



## RobusBrew™ BREW SEPARATOR UNIT

- First development and commercialization in Korea
- Improved productivity with filtration capacity (4,000L / 1hr)
- Compact Size
- Prompt technical support and service

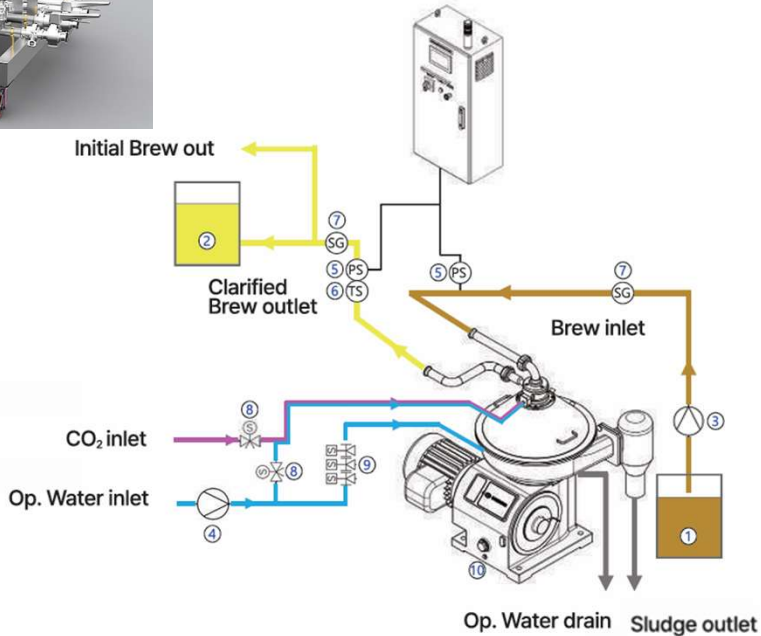

### General

- Feed brew Temperature : 0°C ~ 10°C
- Ambient Temperature : 0°C ~ 30°C
- brew Outlet delivery head : Max. 2.5bar
- Main supply voltage : 380V or as customer's requirement
- Control voltage : DC24V

### Motor

- Type : Totally Enclosed Fan Cooled
- Power : AC380V, 60Hz, 3Φ
- Output : 7.5kW
- Enclosure : IP55
- Insulation : F-class
- Speed : 1775 RPM
- Remarks : Horizontal Flange Mounting Type

### Water Pump

- Type : Air diaphragm type
- Capacity : Max. 2000L/H

### Control Panel

- Type : Wall Mounting Type, Indoor Use
- Enclosure : IP45

### Feed pump(Optional)

- Capacity : Max. 5000L/H
- Head : Delivery 25m
- Remark : Separated type with inverter

### Customers



02 | Main Business Global Partnership Members



**Skarpenord**★  
A part of Scana



**YOKOGAWA** ◆



 # Head Office : 1316-5, Wolchon-li, Daedong-myeon, Gimhae-si, Gyeongsangnam-Do  
# 2 Factory : 15, Mieumsandan 2-ro 16beon-gil, Gangseo-gu, Busan

 [sales@robustech.co.kr](mailto:sales@robustech.co.kr)

 051-715-7748

 [www.robustech.co.kr](http://www.robustech.co.kr)